



CR. 42AS

1/32 SCALE MODEL KIT No32023

CR. 42AS

Итальянский истребитель-бомбардировщик II MB

CR. 42AS - это одноместный истребитель-полтораплан с непосредственной авиационной поддержкой. Два стандартных 12,7-мм пулемета можно было дополнить еще двумя. Были подкрыльевые стойки для двух бомб по 220 фунтов (100 кг). AS означает «Africa Settentrionale». Был установлен дополнительный фильтр двигателя, чтобы предотвратить повреждение песком, которое привело к потере мощности, что является обычным явлением в Северной Африке, поскольку двигатели без фильтра могут быть повреждены всего через несколько часов использования.

Тактико-технические характеристики CR. 42AS

Длина, м	8,25
Размах крыла, м	9,7
Взлетный вес, кг	2295
Двигатель	Fiat A.74, 840 л.с.
Максимальная скорость, км/ч	441
Потолок, м	10210
Дальность, км	780
Вооружение	2 12,7-мм пулемета Breda-SAFAT

CR. 42AS

WWII Italian Fighter-Bomber

CR. 42AS is a close air-support version of single-seat sesquiplane fighter. The two standard 12.7 mm machine guns could be supplemented with two more. There were underwing racks for two 220 lb (100 kg) bombs. AS stands for 'Africa Settentrionale'. There was an additional engine filter to prevent damage from sand, which caused a loss in power, a common occurrence in North Africa, since filter-less engines could be damaged after only a few hours use.

Tactical and Technical Specifications of CR. 42AS

Length, m	8,25
Wingspan, m	9,7
Start Weight, kg	2295
Engine	Fiat A.74, 840 hp
Max. Speed, km/h	441
Service Ceiling, m	10210
Range, km	780
Armament	2 12,7 mm Breda-SAFAT machine guns

ИСПОЛЬЗУЕМЫЕ КРАСКИ / USED COLORS:

COLOR	Revell	Tamiya
A Черный, матовый Flat Black	108	XF1
B Белый, матовый Flat White	105	XF2
C Темно-зеленый, матовый Dark Green	168	XF61
D Коричневый, матовый Dark Earth	182	XF52
E Алюминий Aluminium	199	XF16
F Сталь Steel	191	X32
G Темная сталь Gun Metal	109	X10

COLOR	Revell	Tamiya
H Светло-серый Light Grey	176	XF66
J Красный, прозрачный Clear Red	731	X27
K Зеленый, прозрачный Clear Green	161	X25
L Ржавчина Rust	137	X34
M Песочный, матовый Desert Yellow	116	XF59
N Красный, матовый Flat Red	136	XF7

01 СТАДИЯ СБОРКИ ASSEMBLY STEP

03 СБОРОЧНАЯ ЕДИНИЦА ASSEMBLY UNIT

ПРИ СБОРКЕ НЕ ИСПОЛЬЗУЕТСЯ PARTS NOT FOR USE

A ИСПОЛЬЗУЕМАЯ КРАСКА USED COLOR

? ПРОИЗВОЛЬНЫЙ ВЫБОР OPTIONAL

* СДЕЛАТЬ САМОМУ SCRATCH BUILD

x2 СДЕЛАТЬ ДВЕ ДЕТАЛИ MAKE 2 PCS

НЕ КЛЕИТЬ DO NOT CEMENT

ПРОСВЕРЛИТЬ OPEN HOLE

ВНИМАНИЕ!
Перед сборкой внимательно прочитайте руководство по монтажу. Каждая деталь пронумерована. Соблюдать последовательность монтажа. Необходимые рабочие инструменты: нож и напильник для зачистки деталей; резиновая лента, клейкая лента и зажимы для сушки белья для прижимания склеиваемых деталей. Детали из пластика очистить в растворе мягкого моющего средства и высушить на воздухе для того, чтобы краска и переводные картинки лучше прилипали. Перед приклеиванием проверить, подходят ли детали; клей наносить экономно. Хром и краску удалить с поверхностей склеивания. Небольшие детали покрасить перед тем, как они будут удалены из рамок. Краску необходимо хорошо просушить, только после этого продолжать сборку. Каждую соответствующую переводную картинку отдельно вырезать и примерно на 20 секунд окунуть в теплую воду. На обозначенном месте картинку отделить от бумаги и прижать промокающей бумагой.

СУТОЧНО!
Read the instructions thoroughly prior to assembly. Each component is numbered. Adhere to specified sequence of assembly. Tools required: knife and file for removal of components from frame; rubber bond, adhesive tape and clothes pegs for clamping components together after applying adhesive. Clean plastic components in a mild detergent solution and allow to air-dry so that paint and transfers adhere better. Prior to applying adhesive, check to see whether the components fit together; apply adhesive sparingly. Remove chrome and paint from the contact surfaces. Paint small components before removing them from the frame. Allow paint to dry well, and only then continue to assemble. Cut out each transfer individually and immerse in warm water for approx. 20 seconds. Slide transfer off paper and into designated position, then press on with blotting paper.

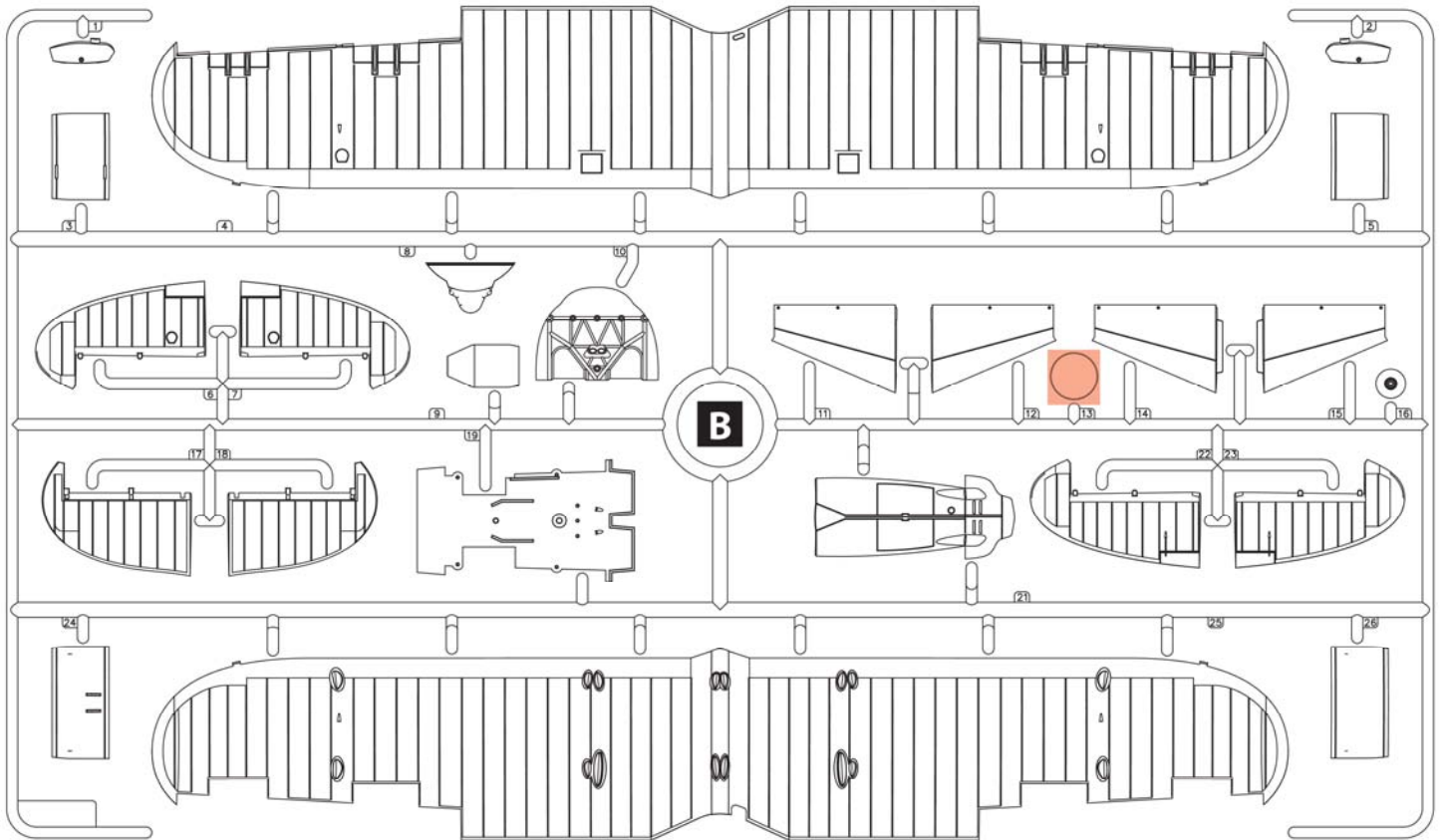
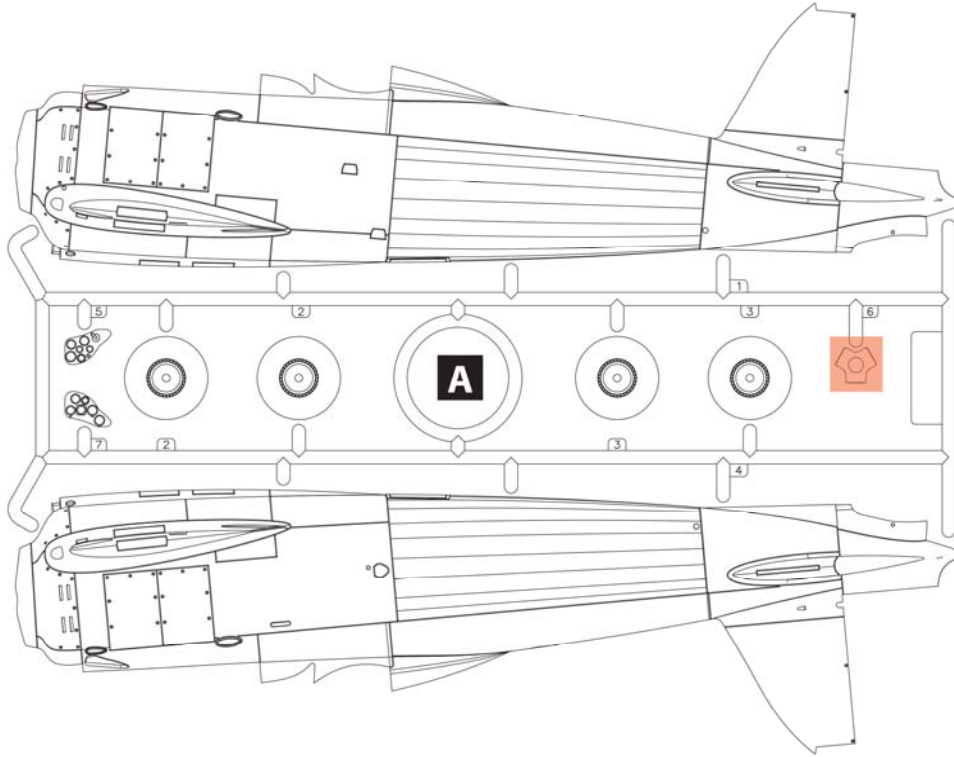

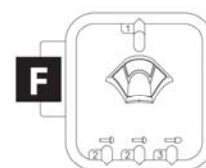
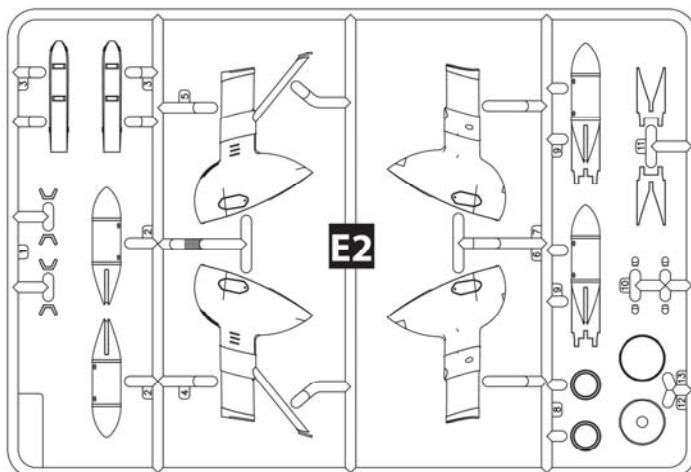
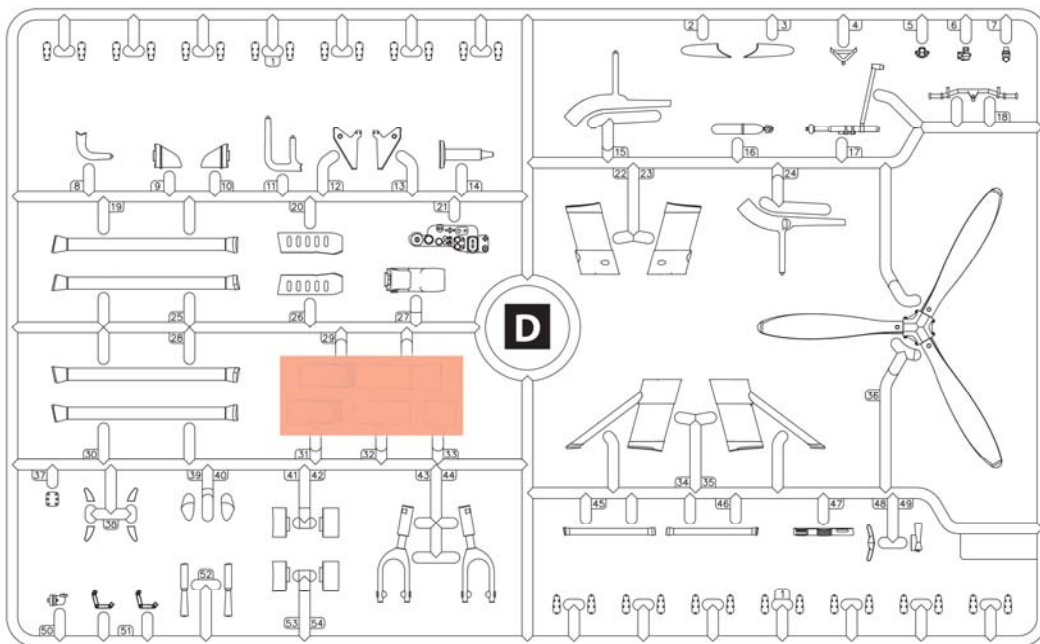
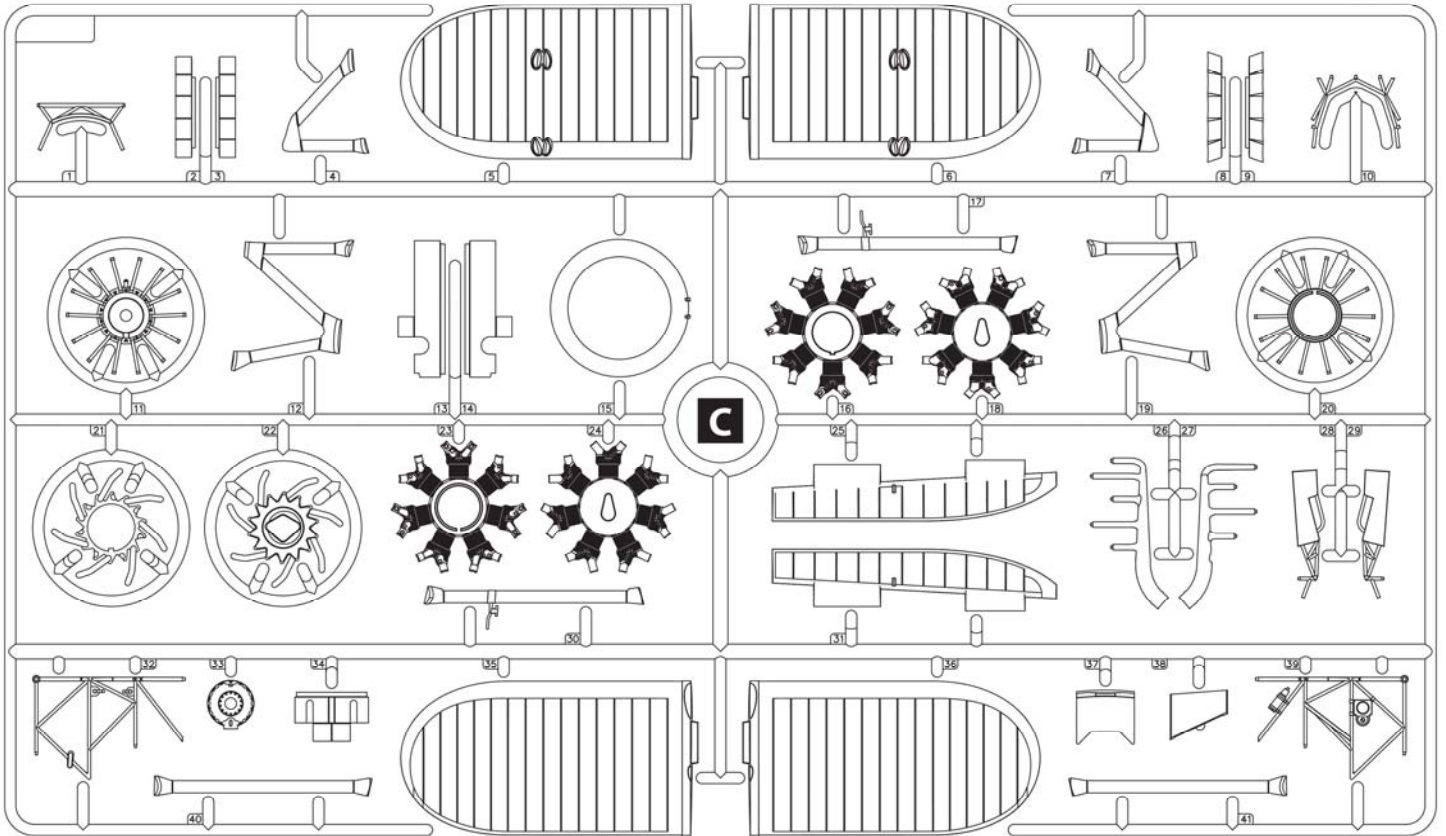

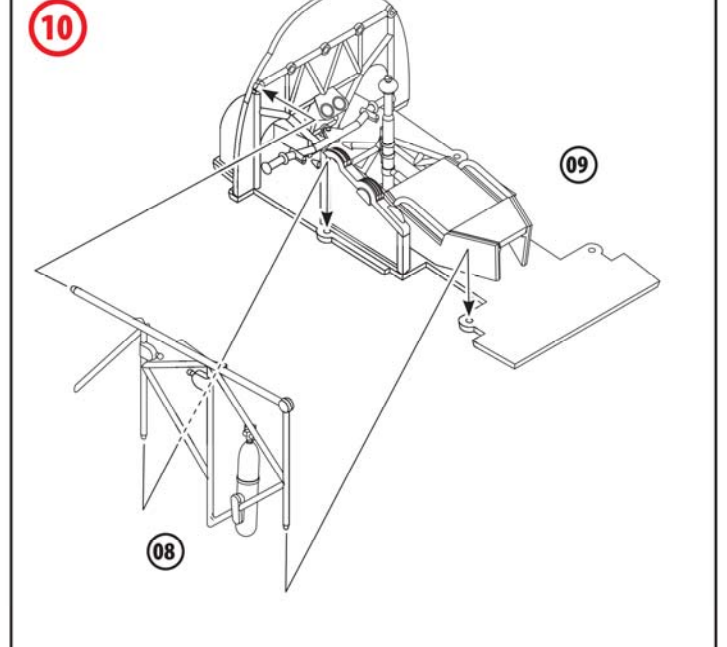
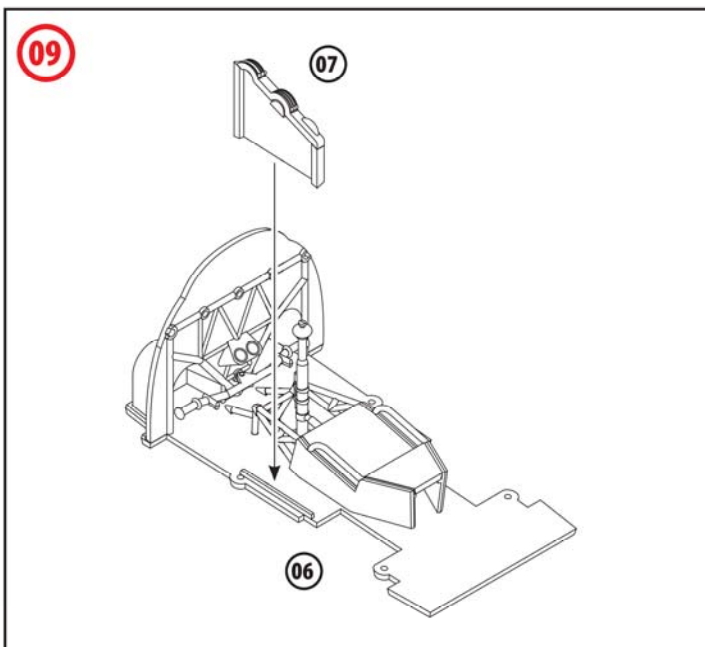
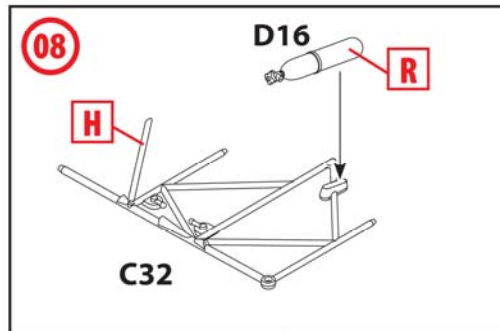
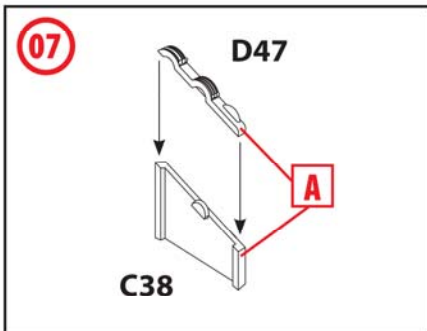
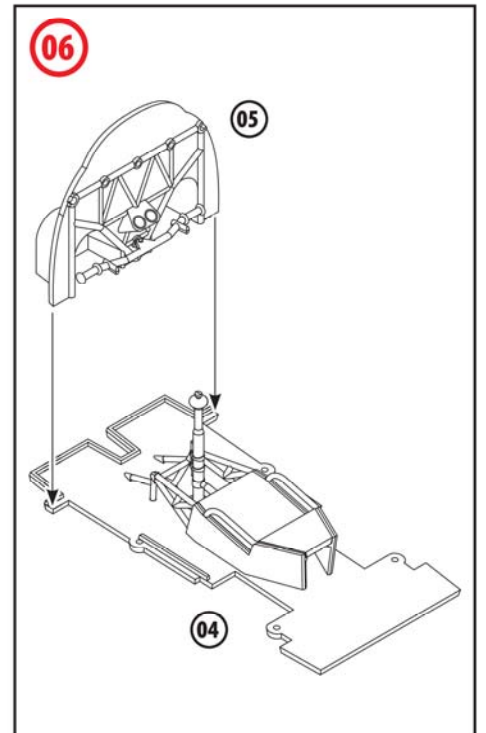
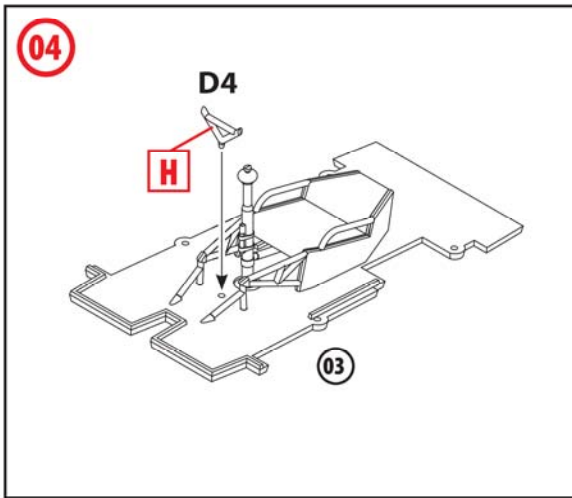
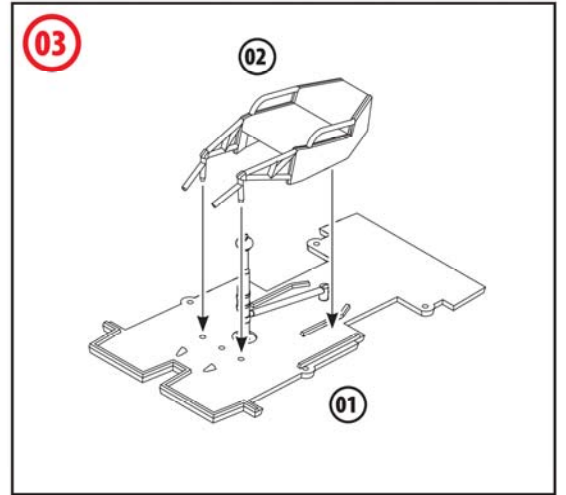
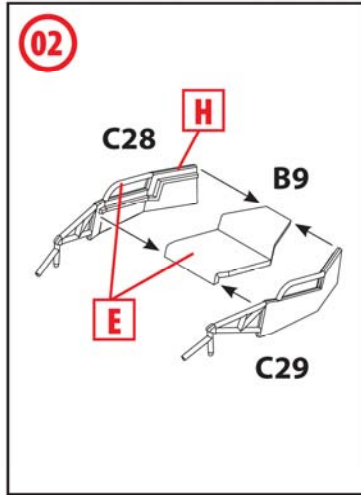
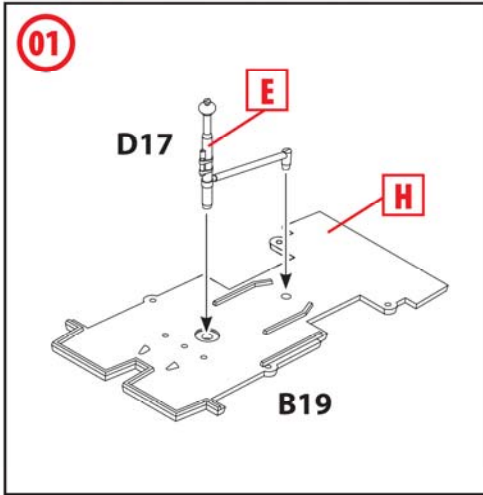

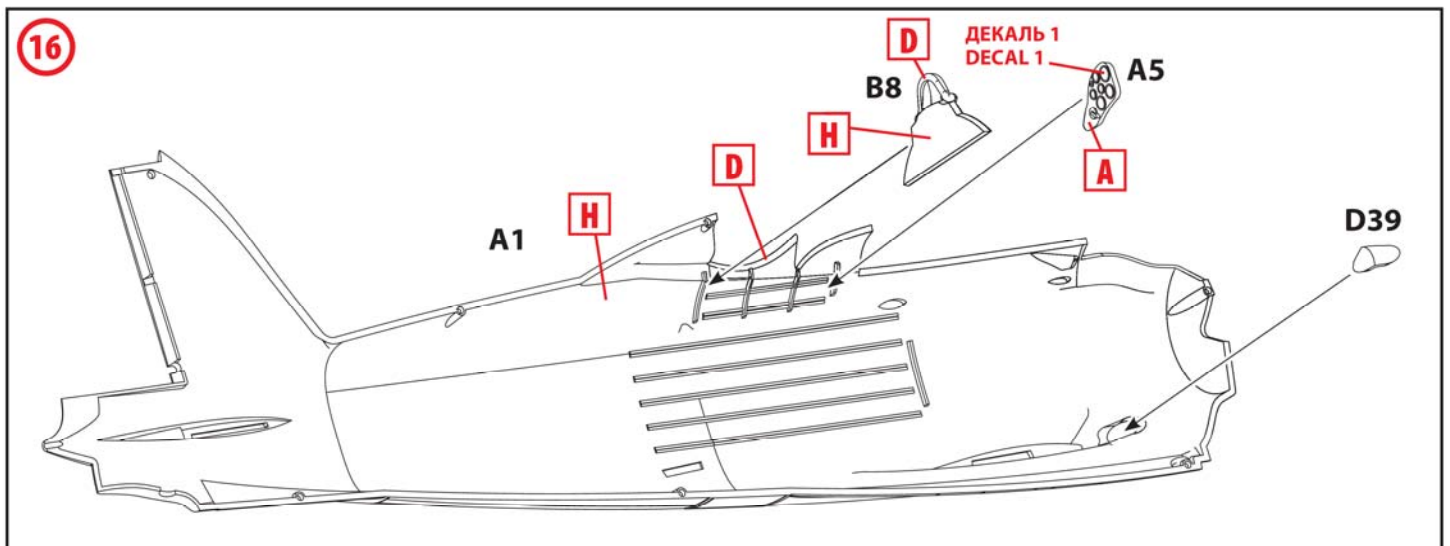
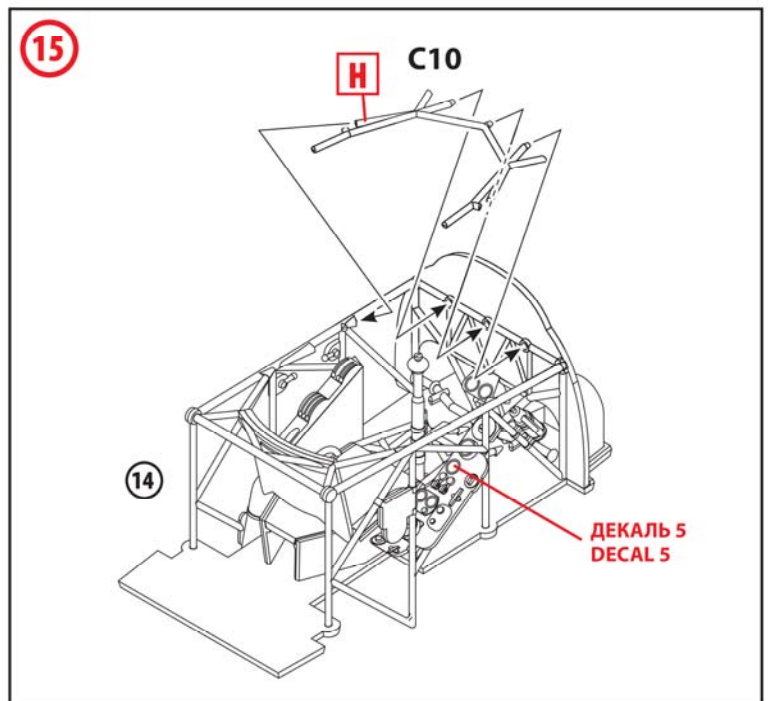
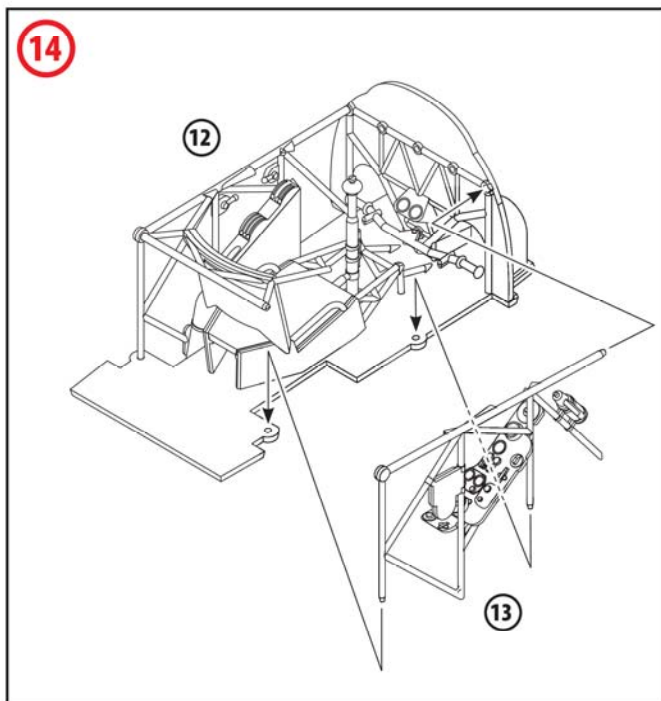
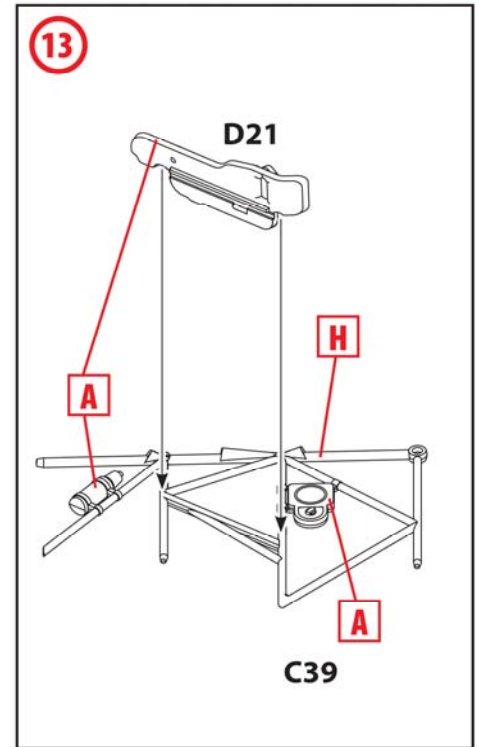
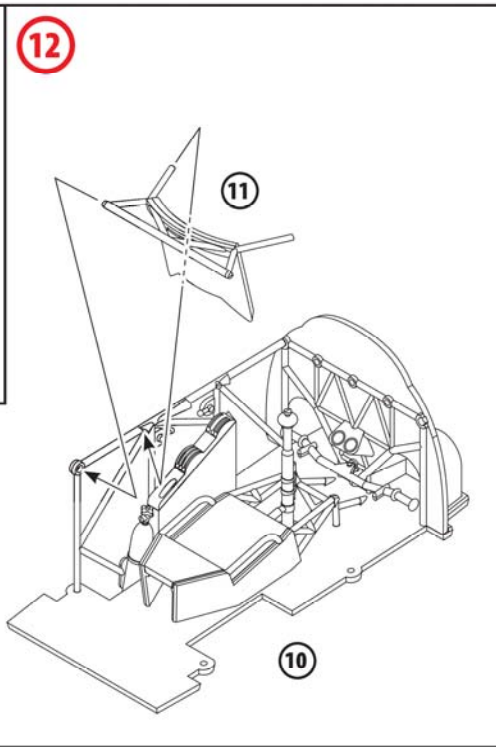
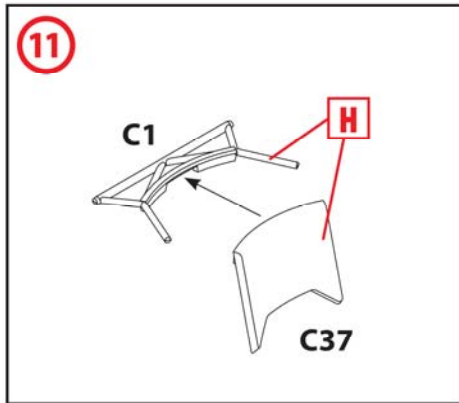

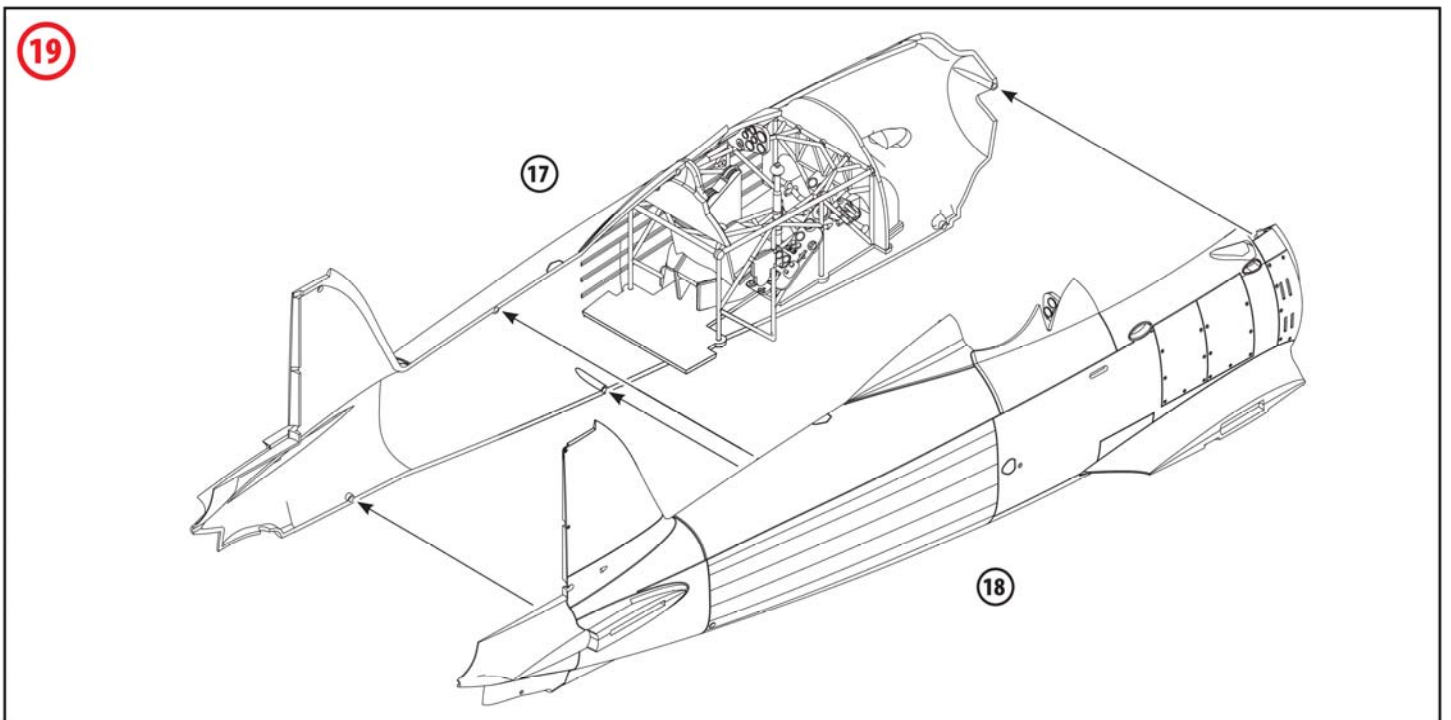
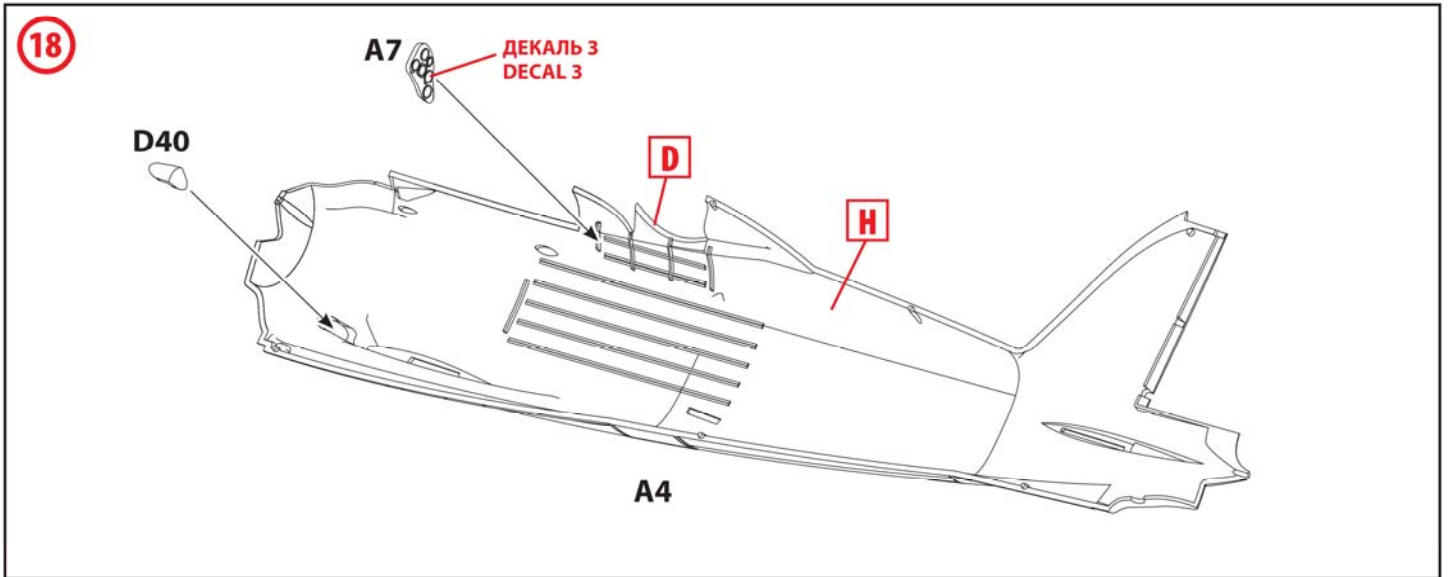
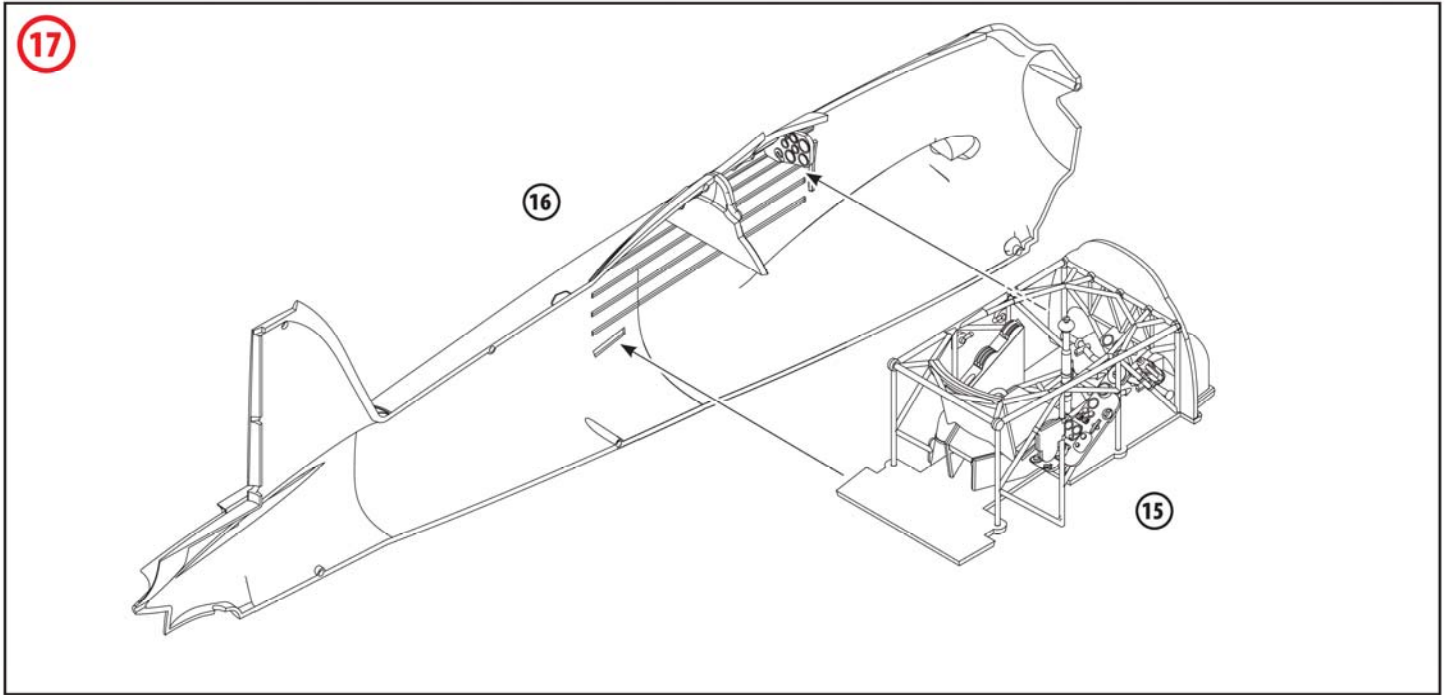

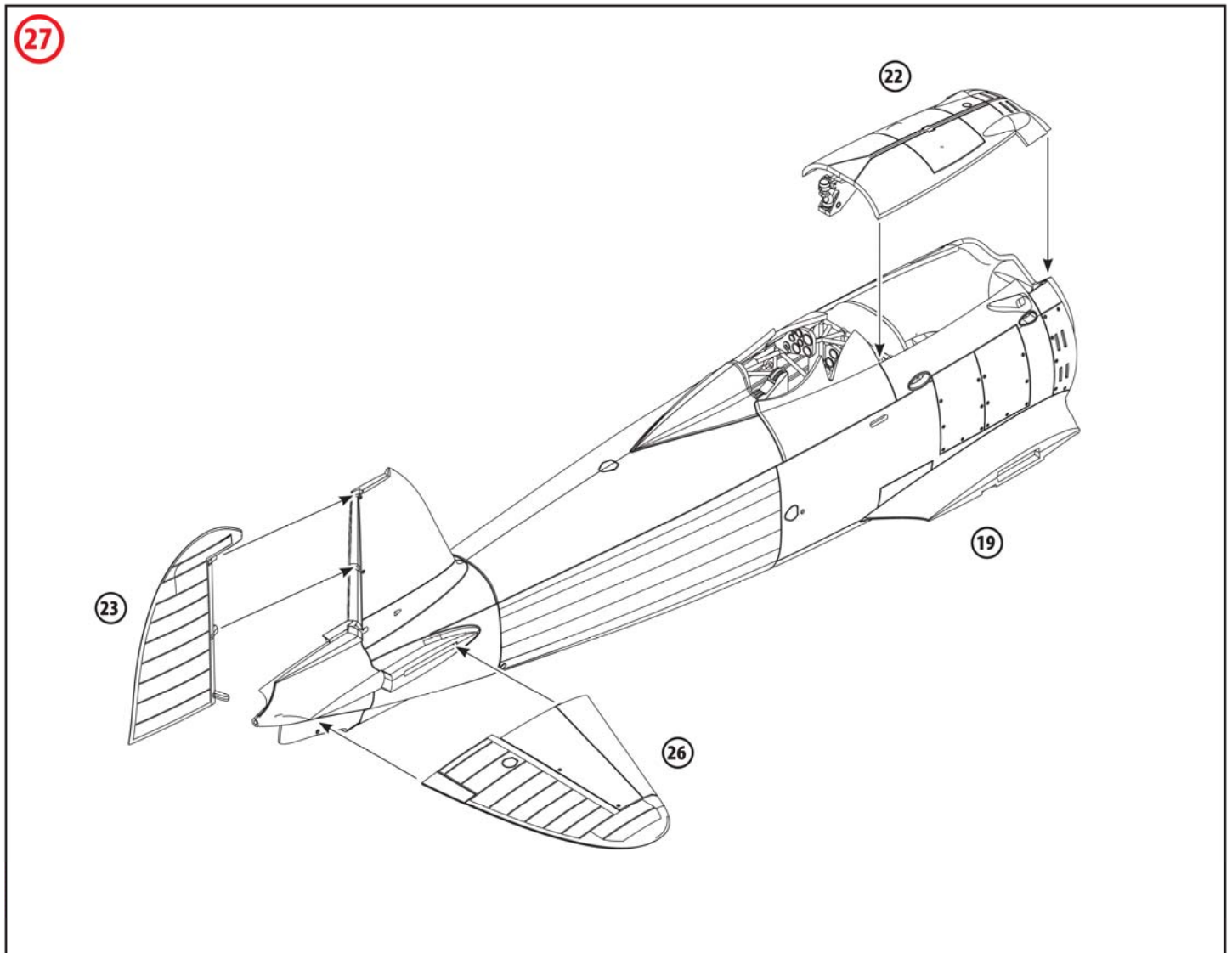
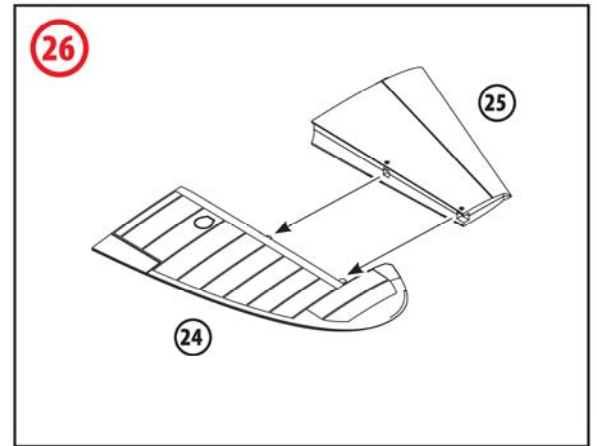
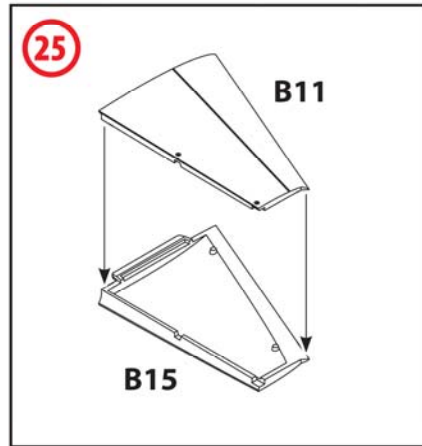
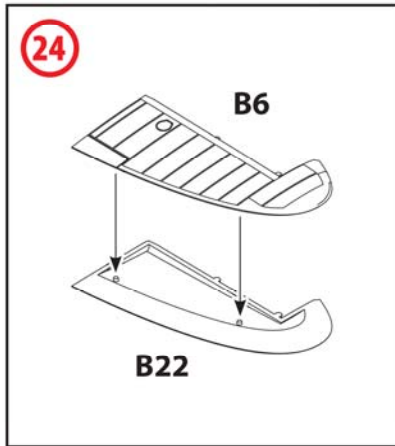
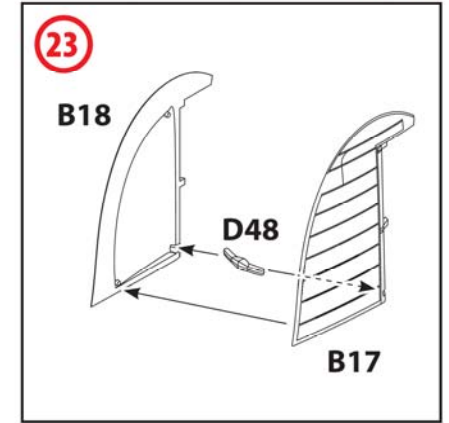
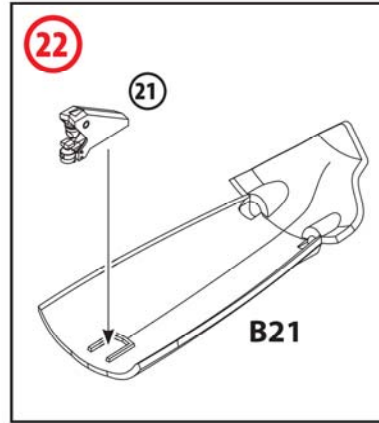
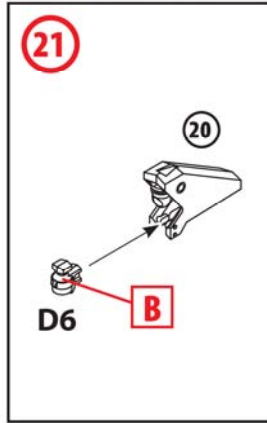

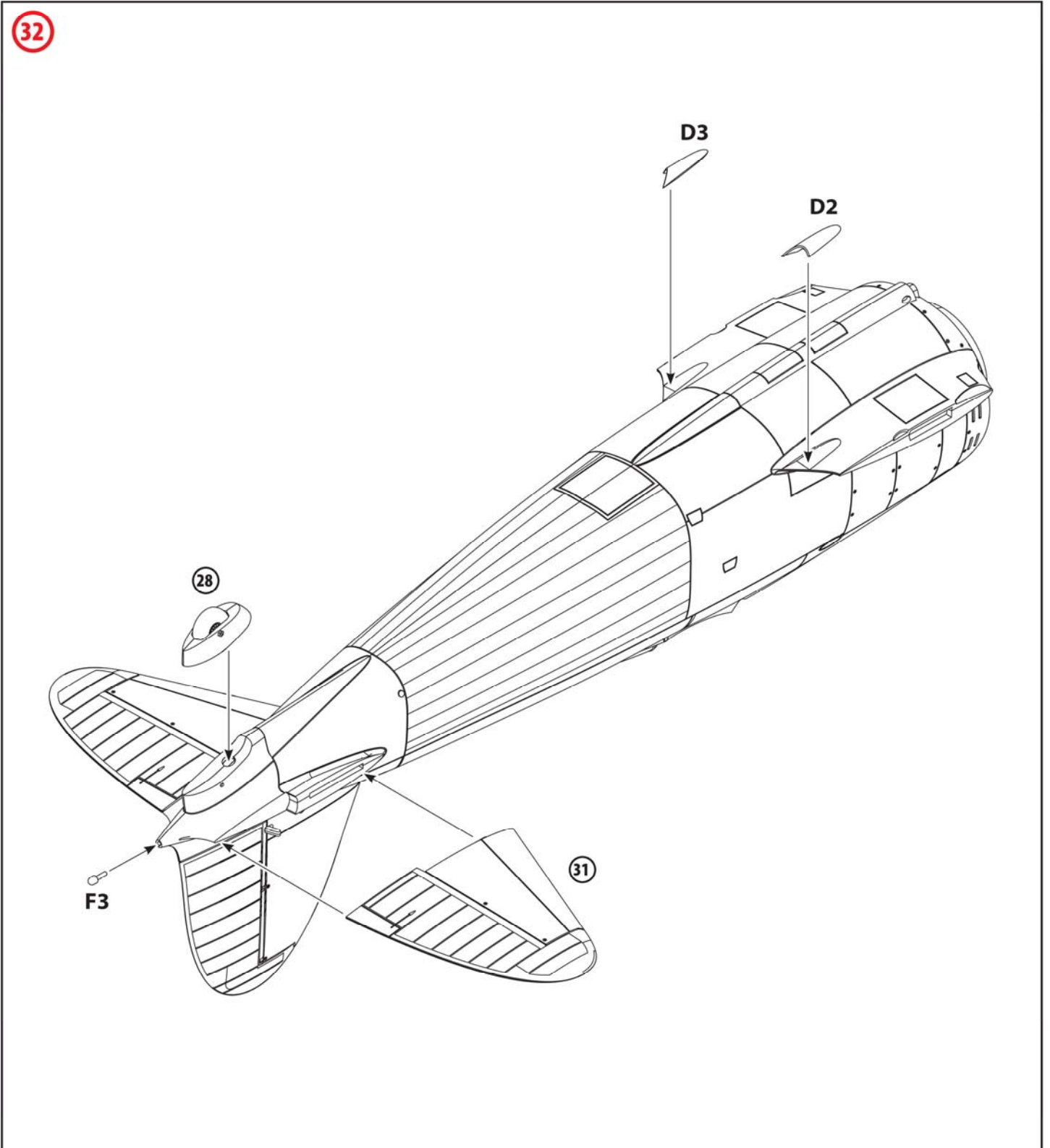
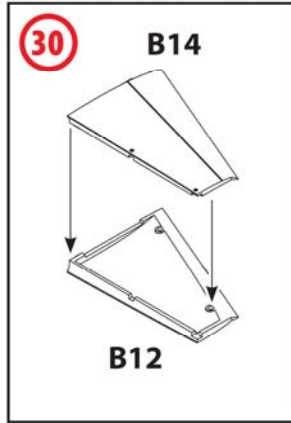
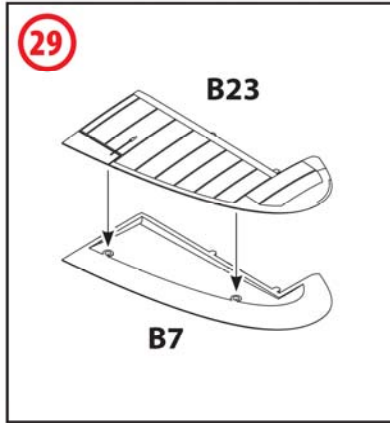
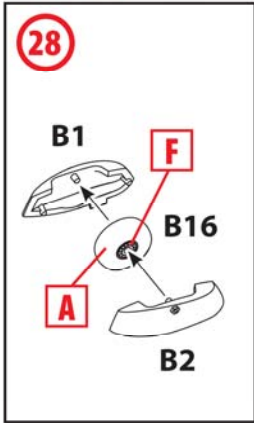

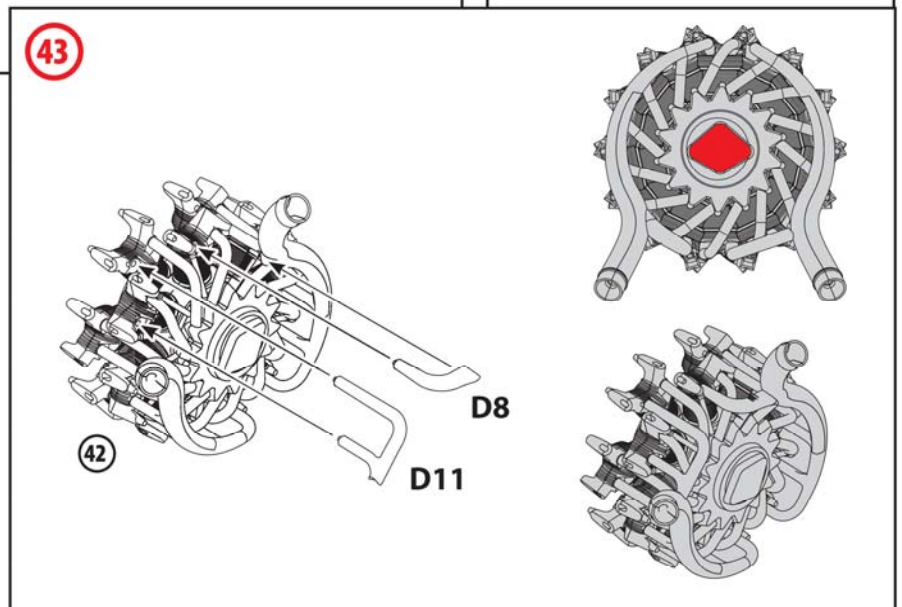
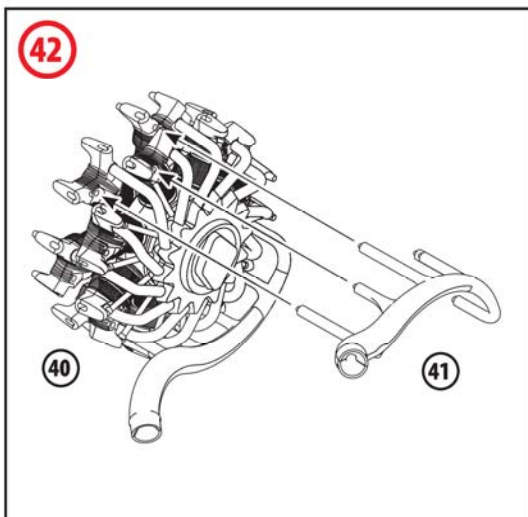
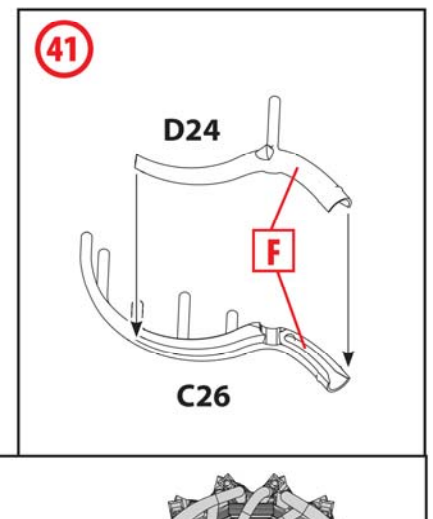
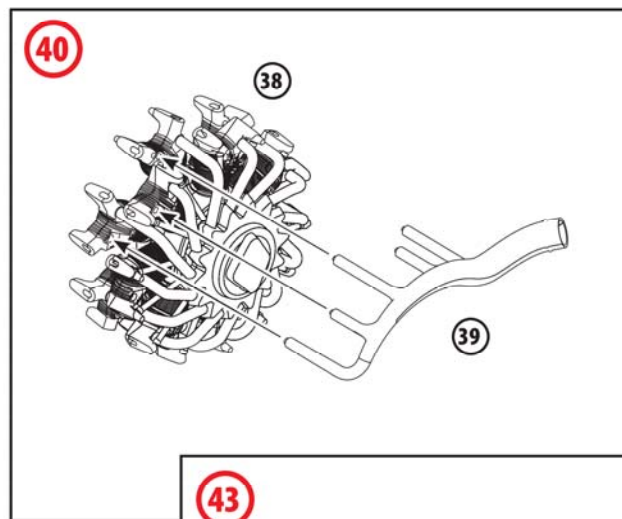
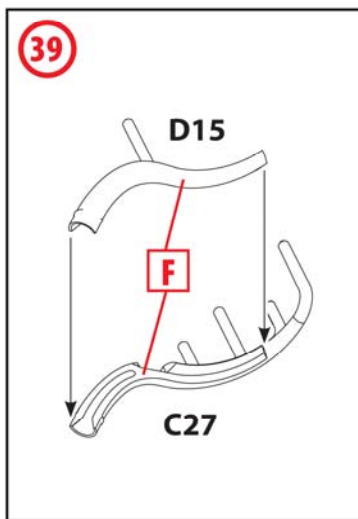
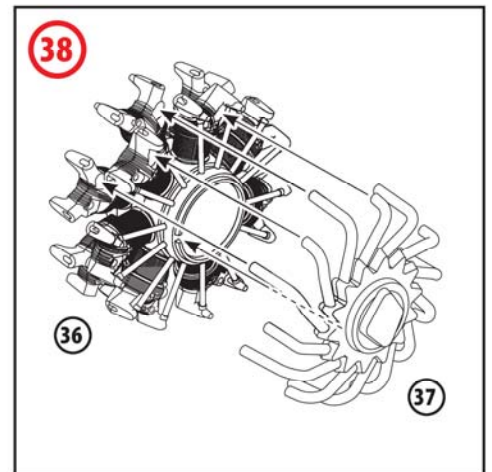
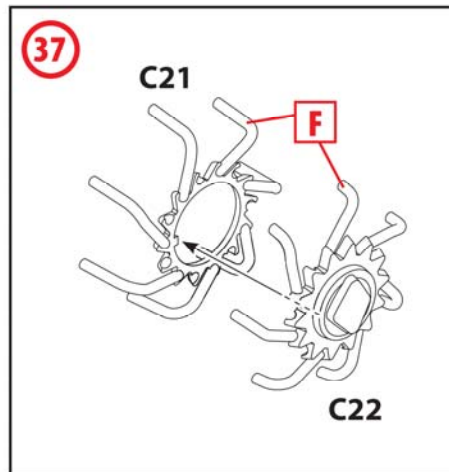
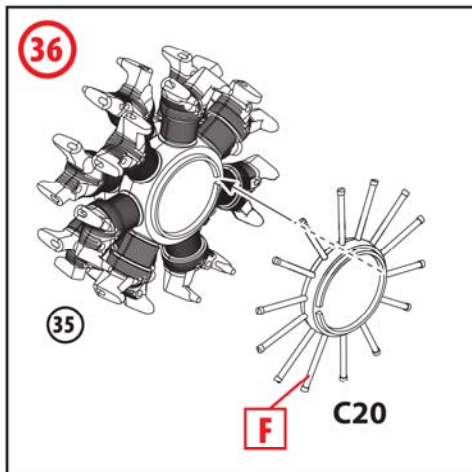
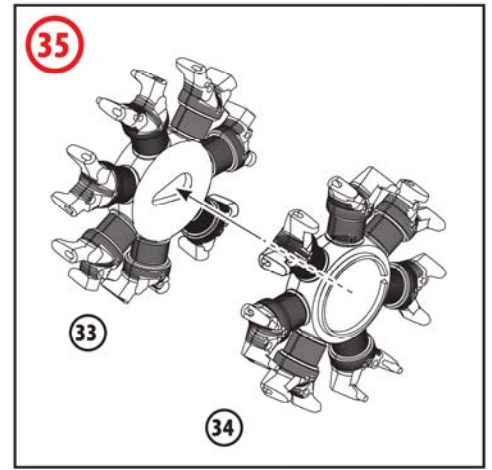
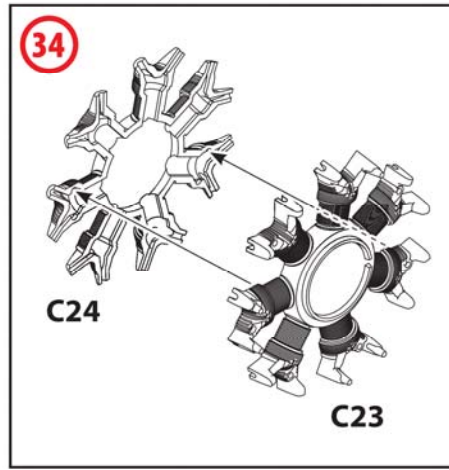
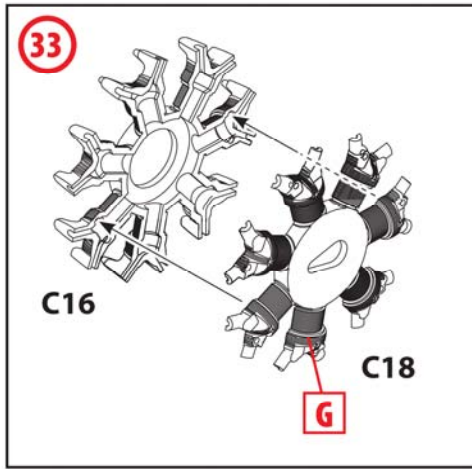

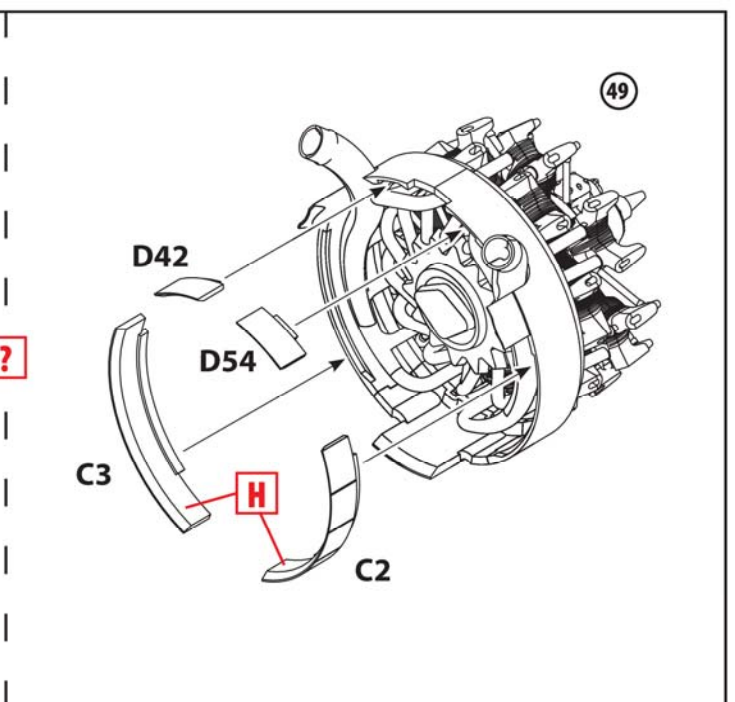
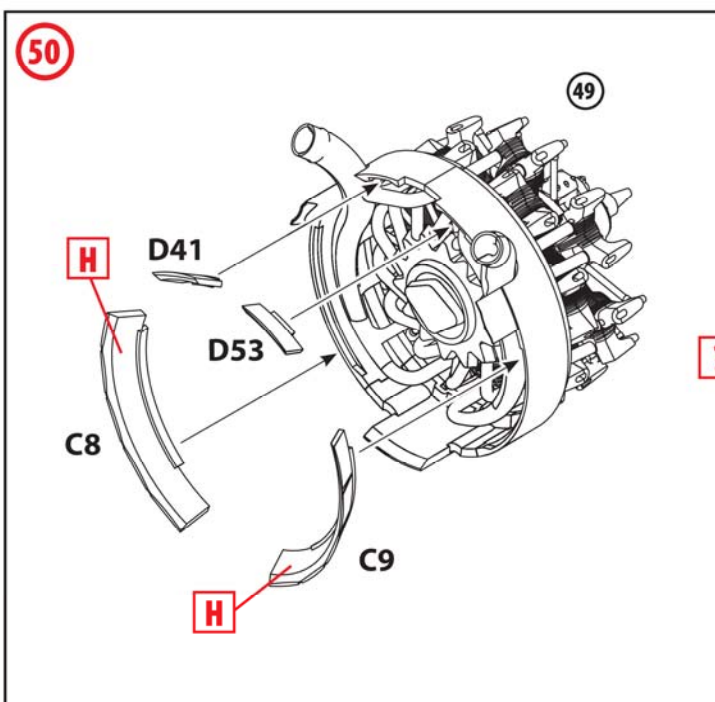
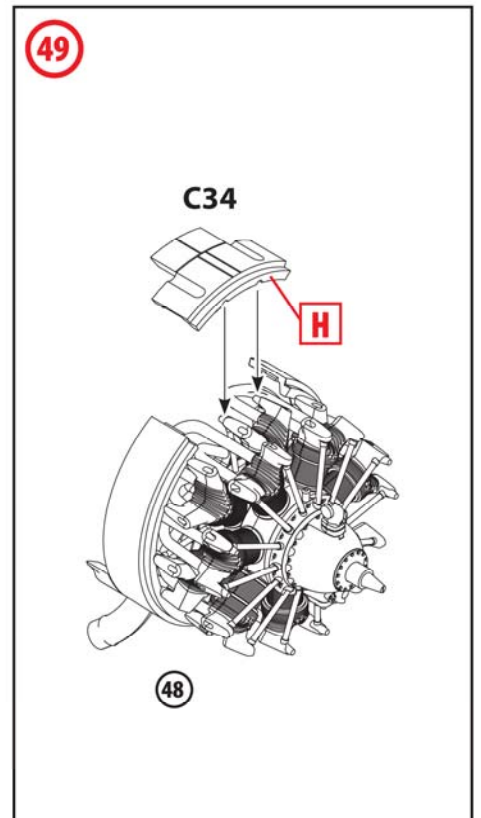
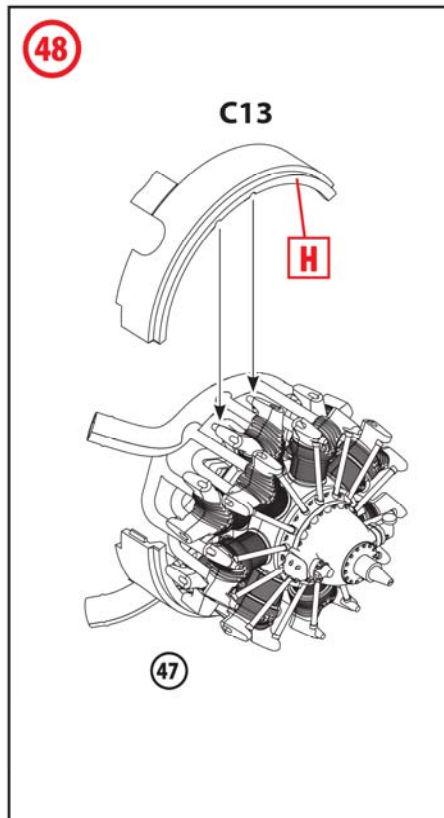
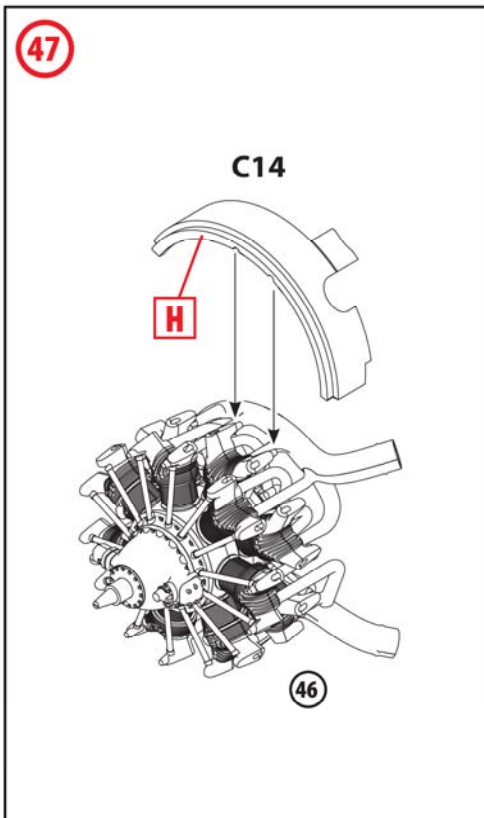
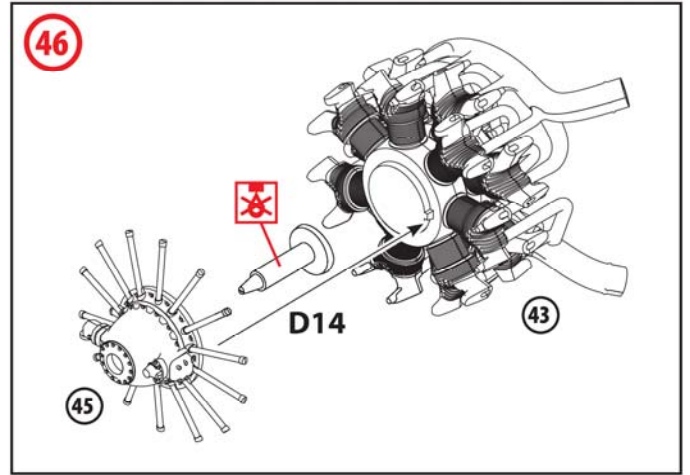
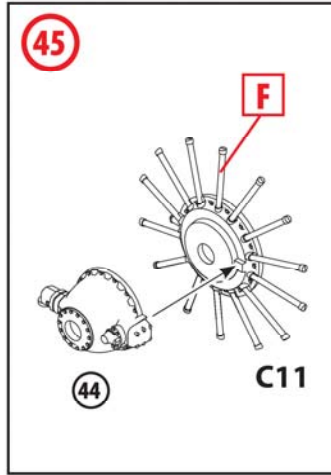
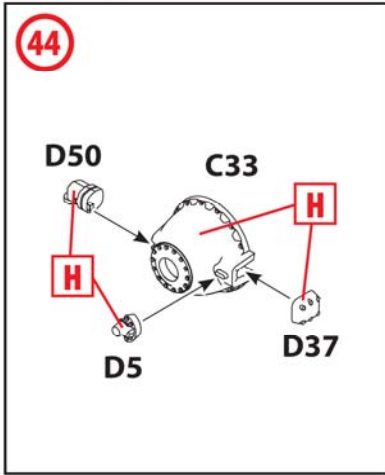

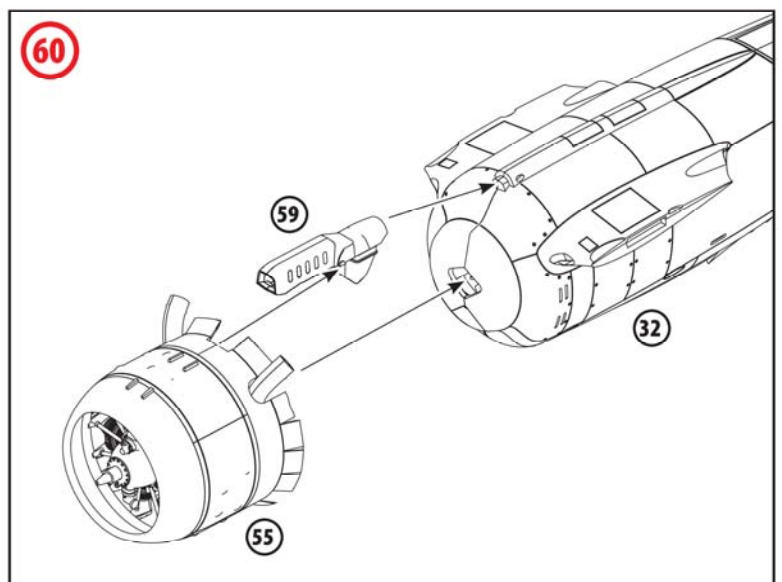
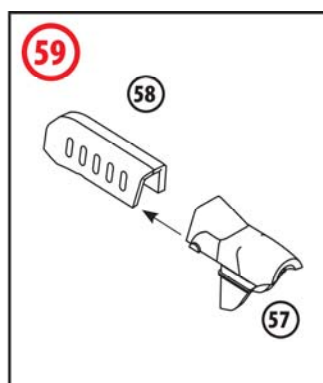
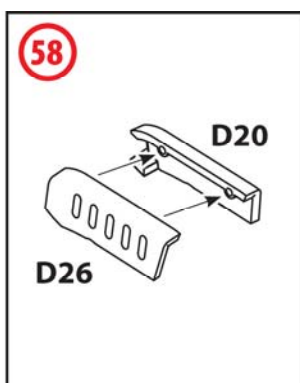
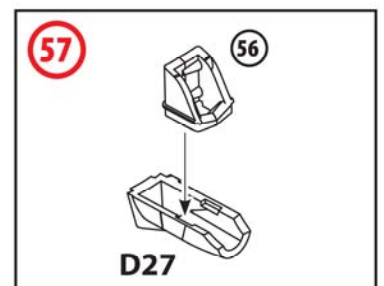
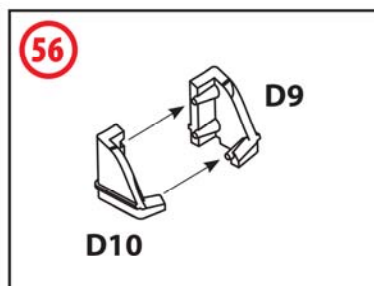
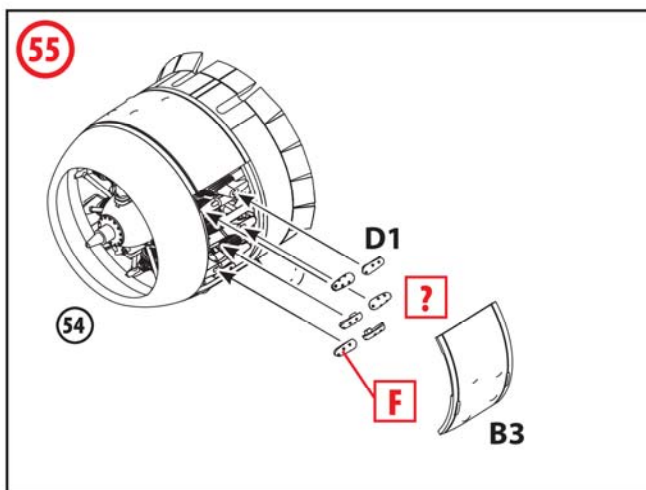
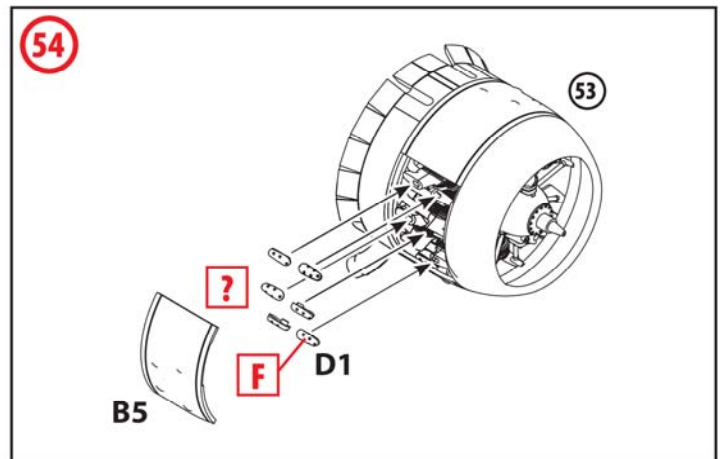
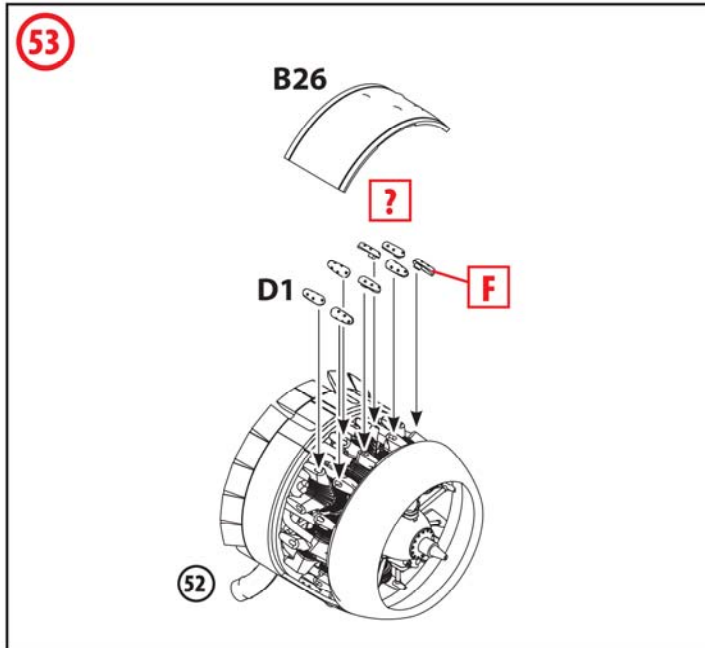
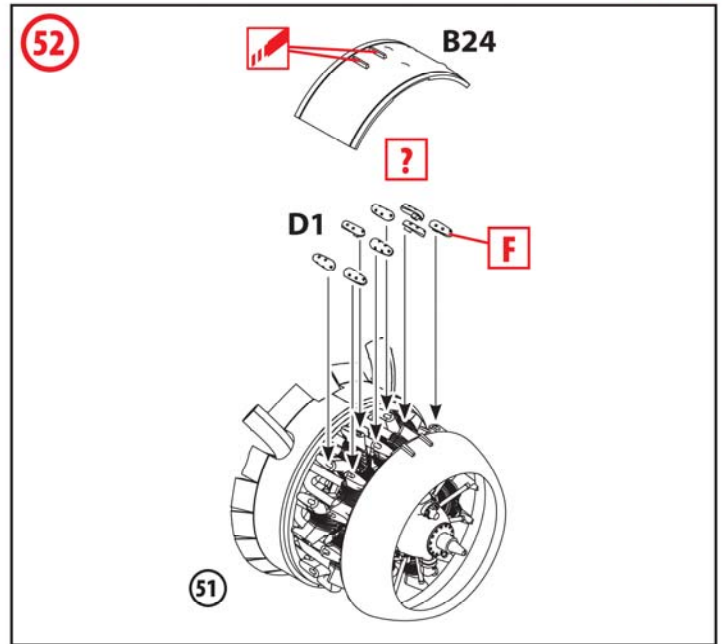
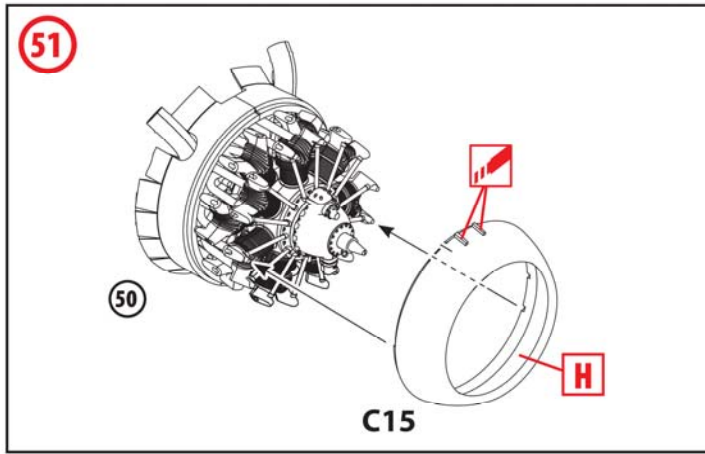

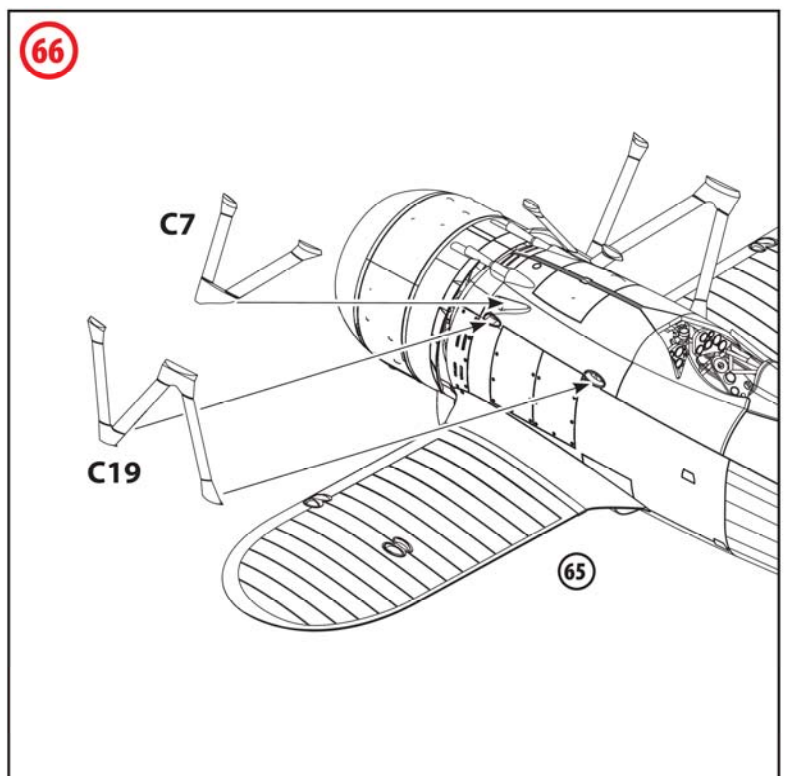
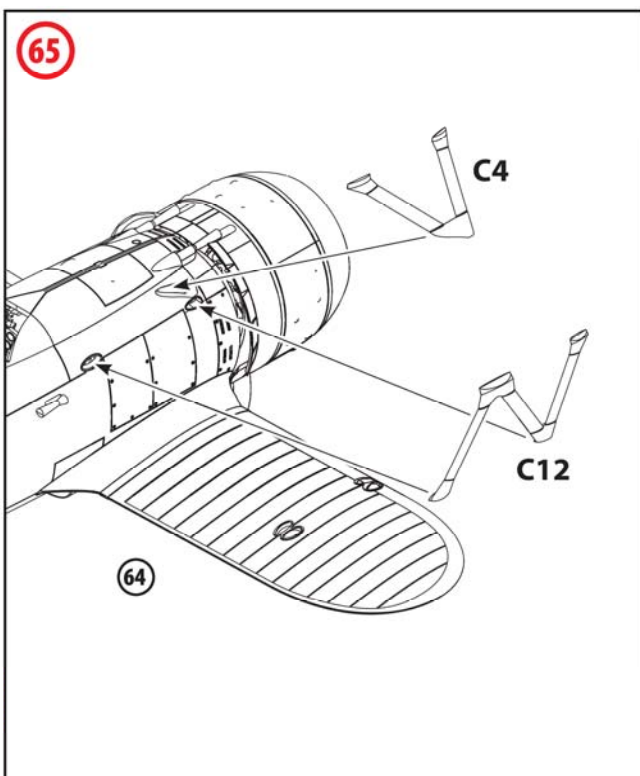
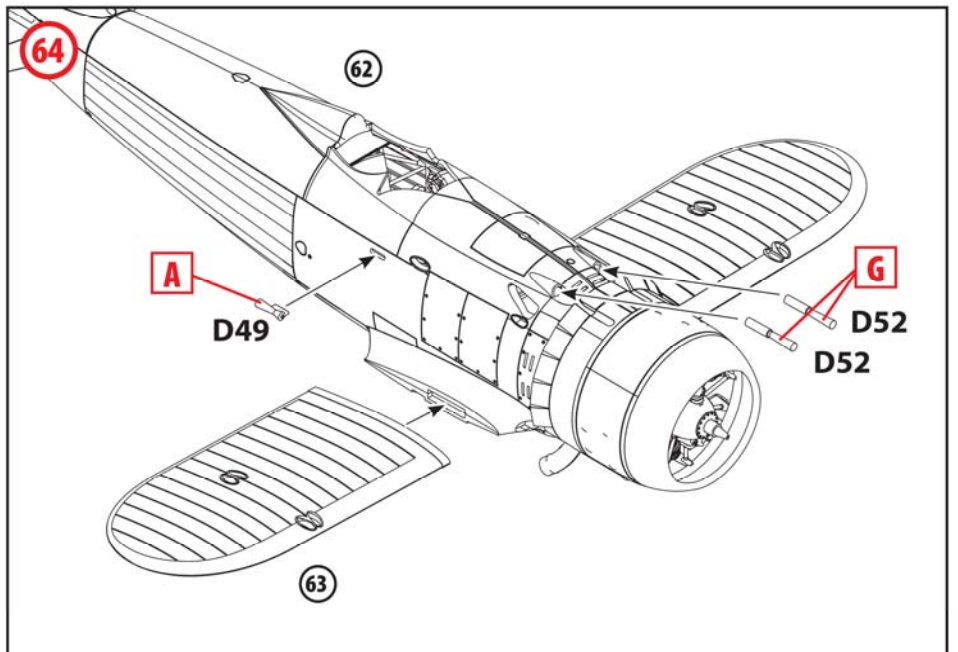
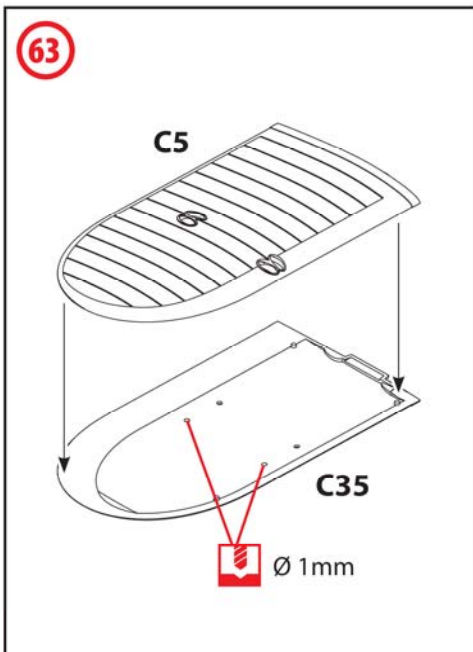
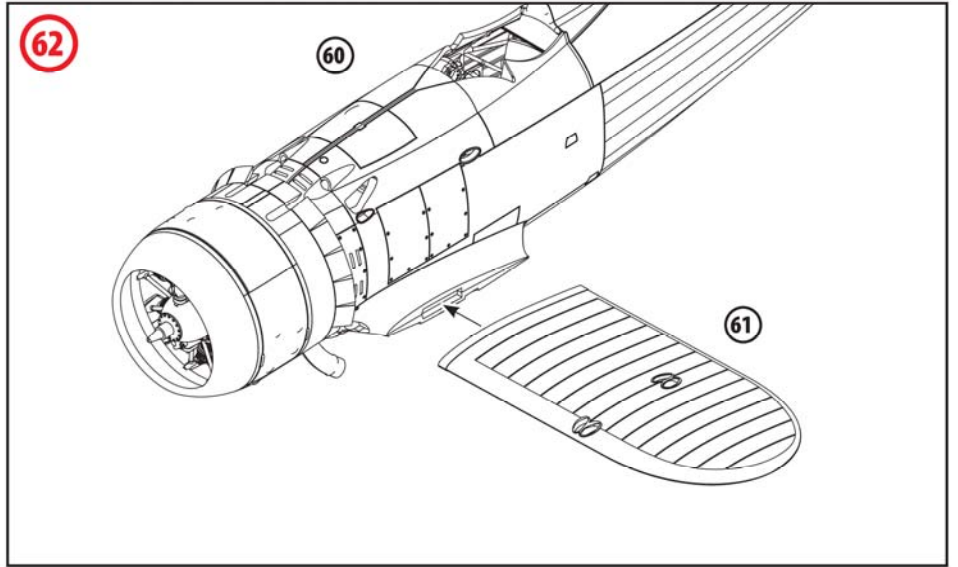
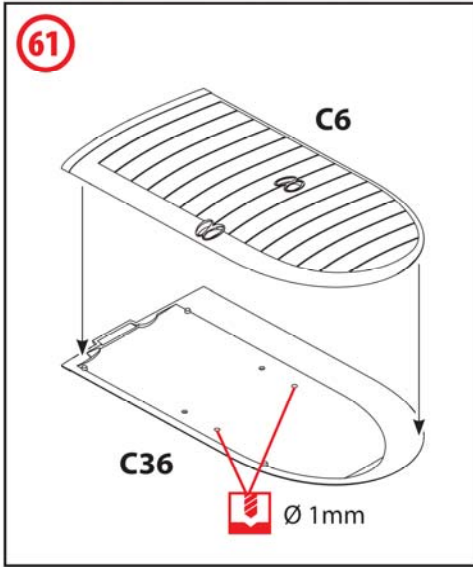

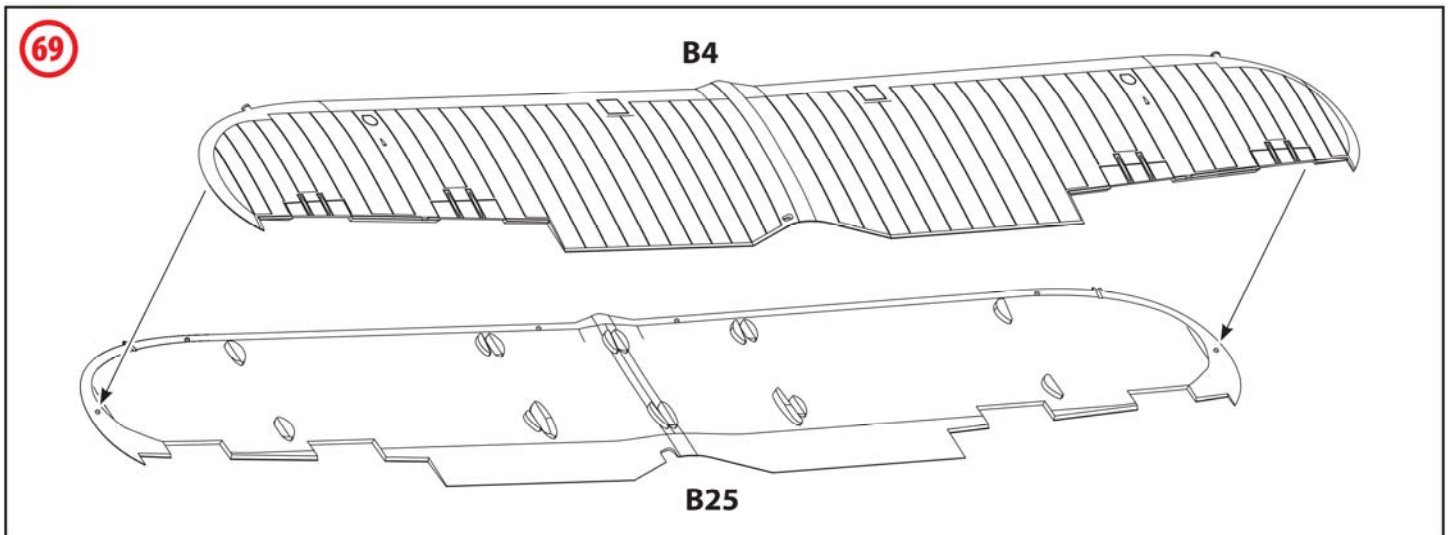
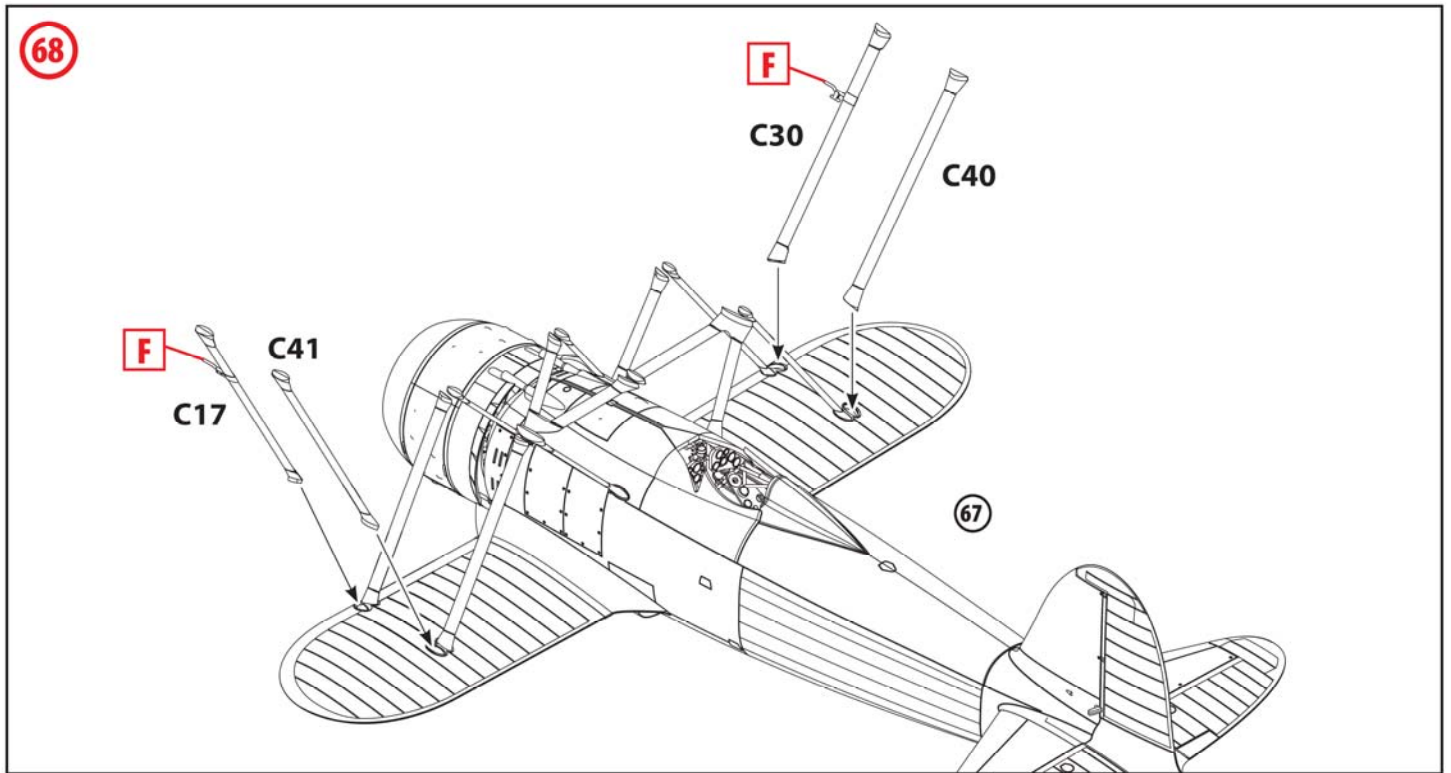
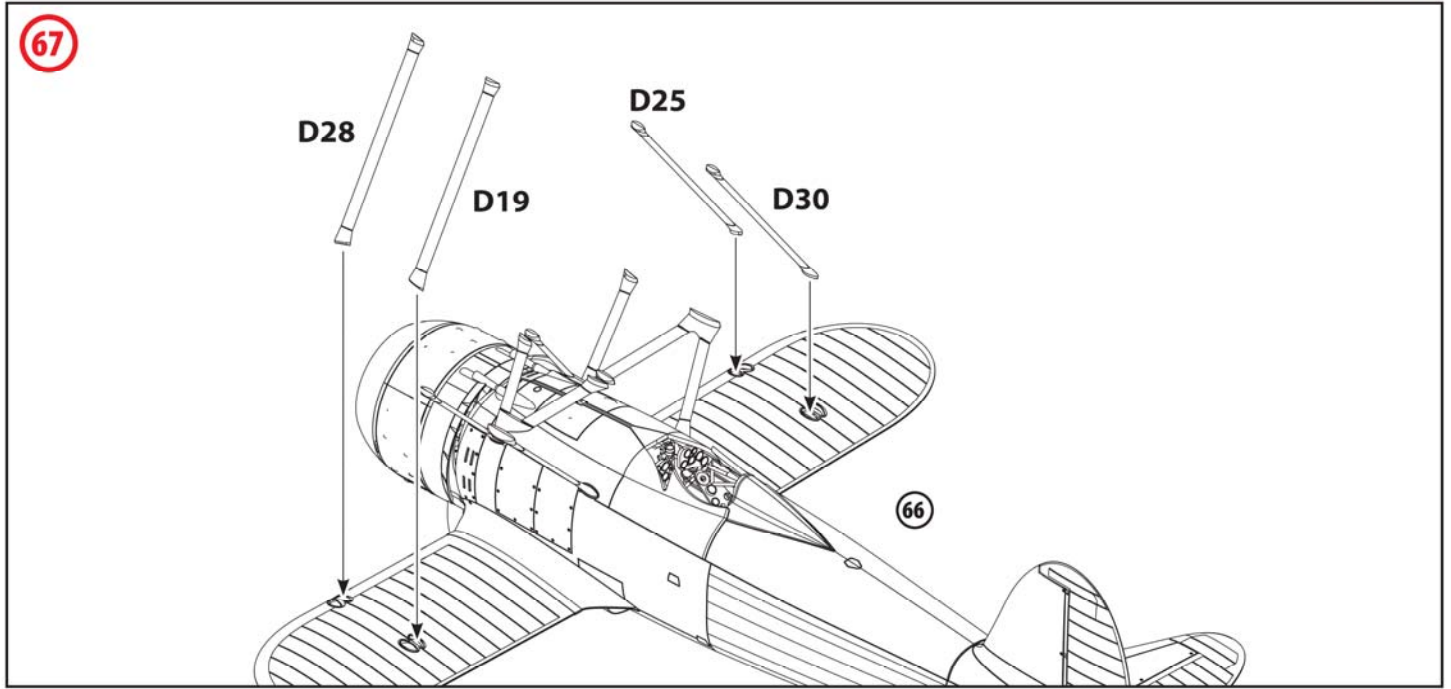

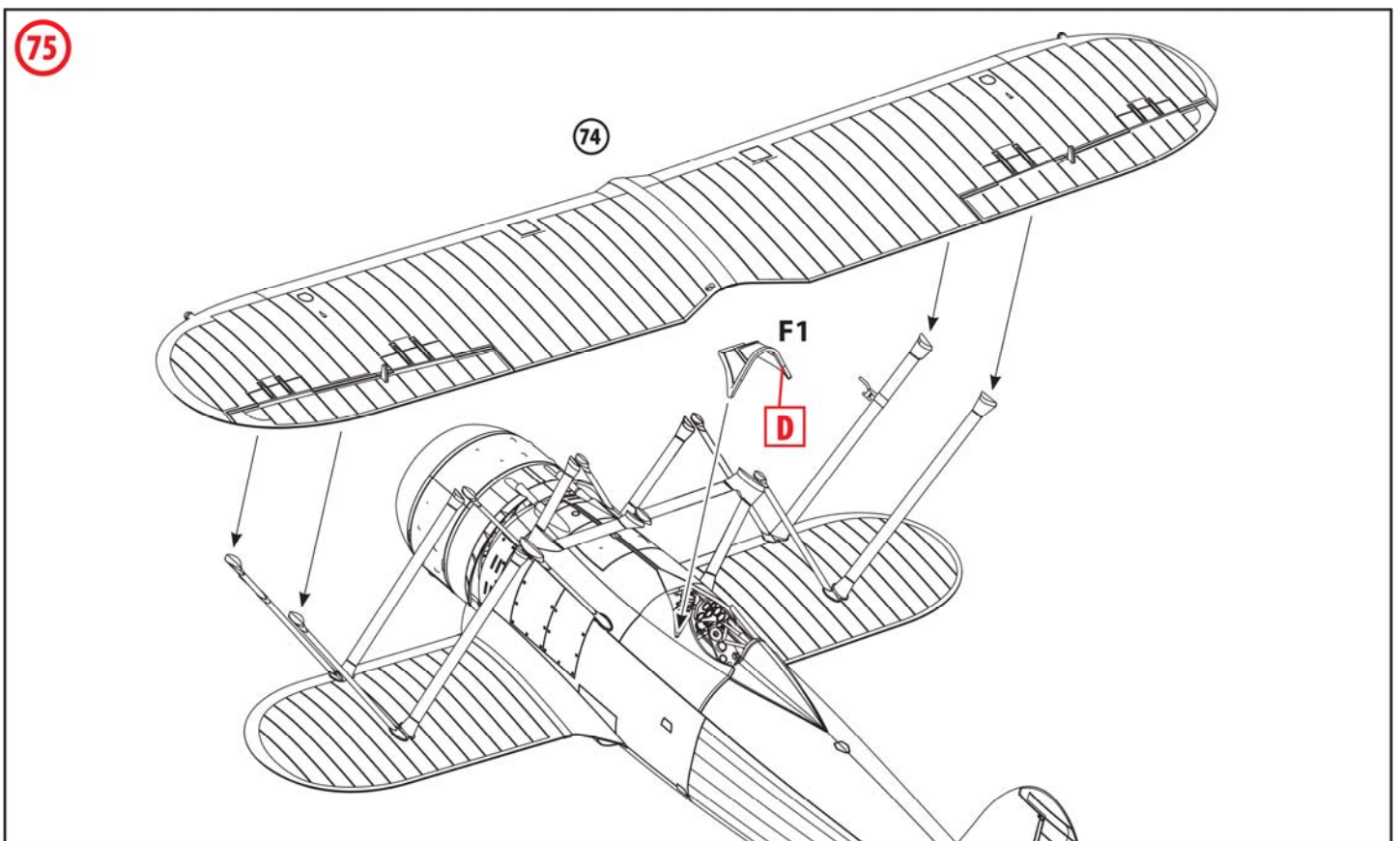
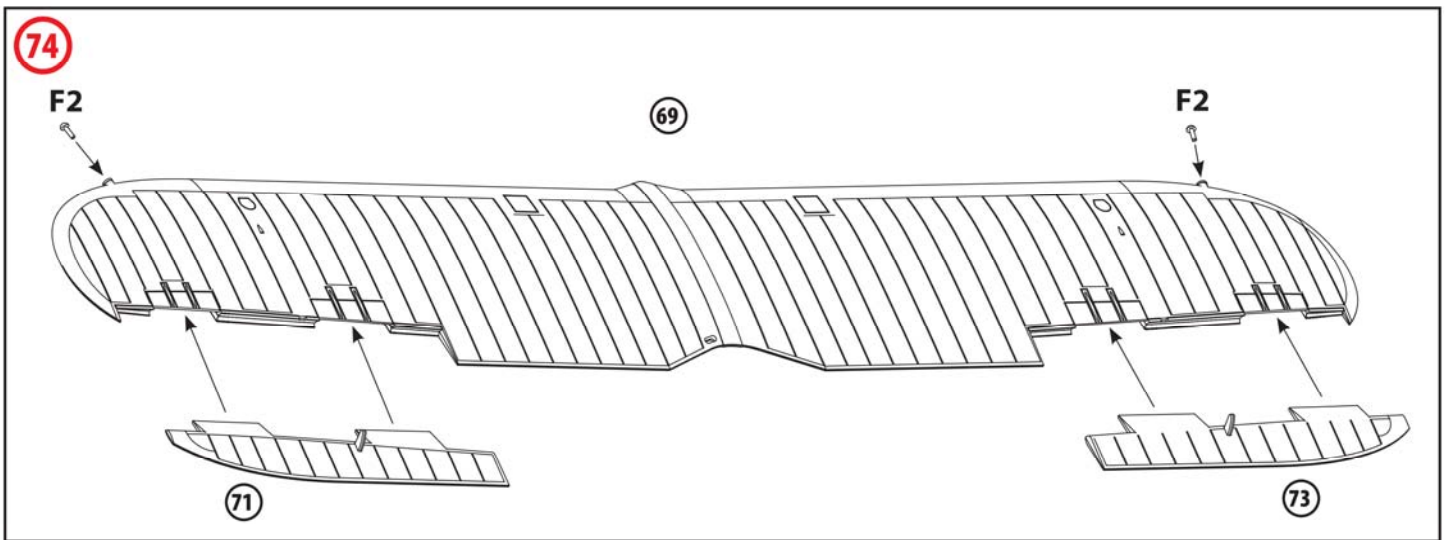
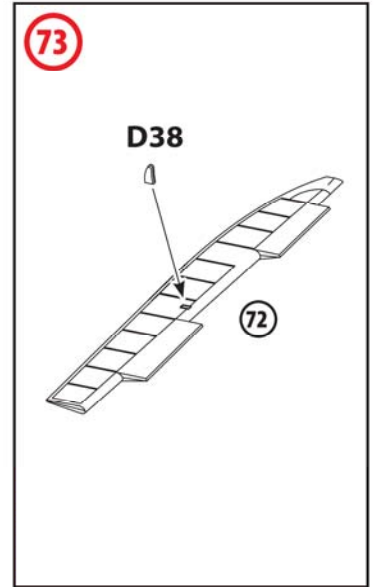
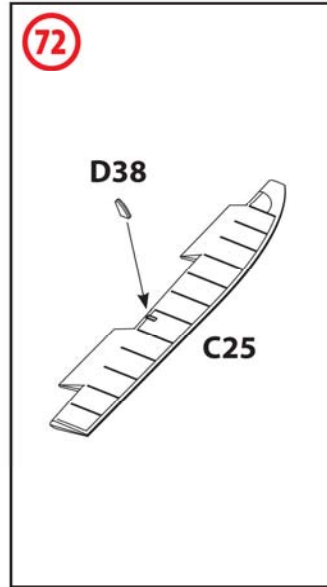
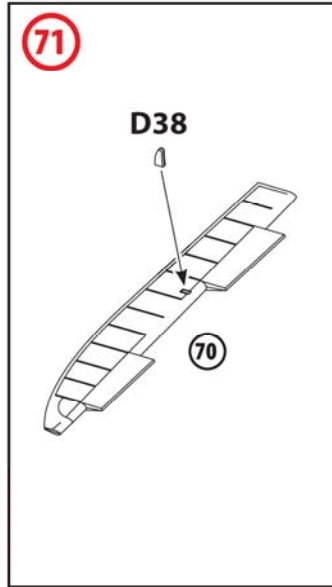
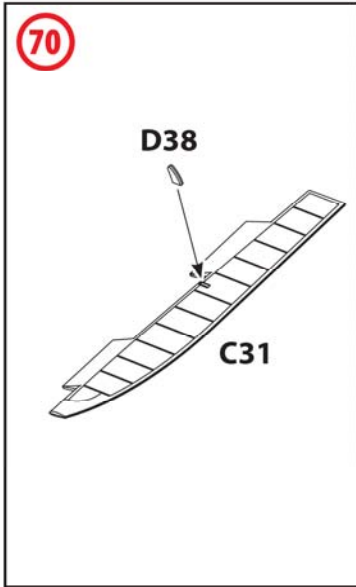

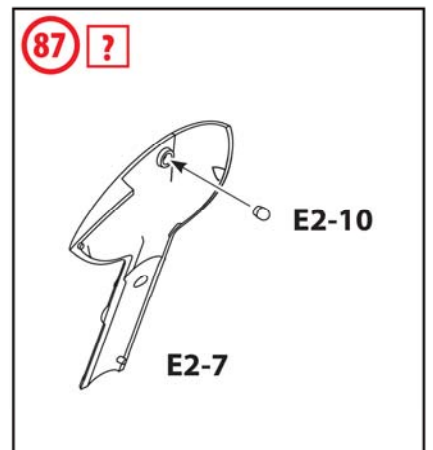
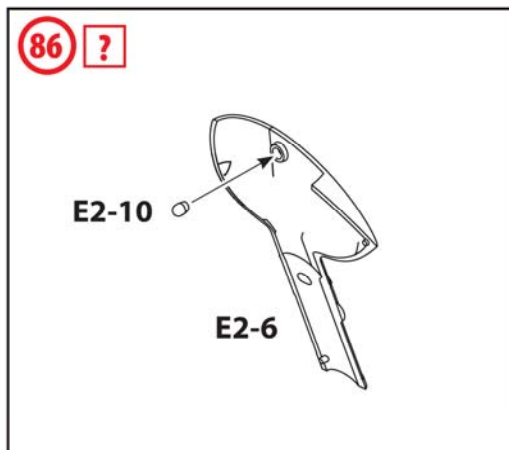
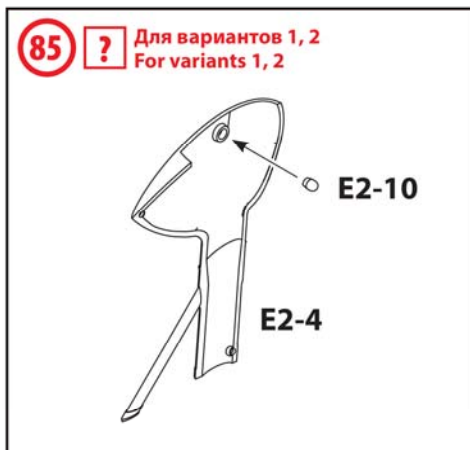
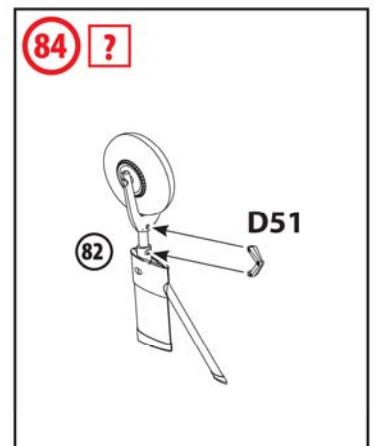
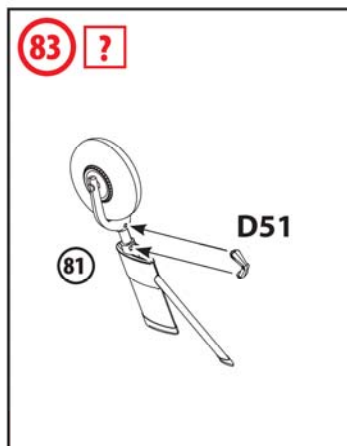
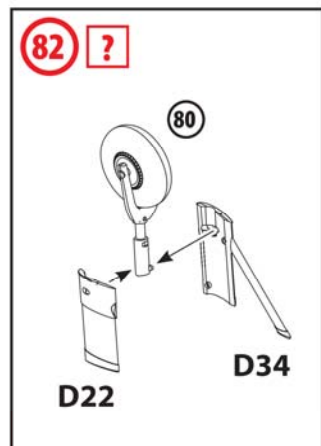
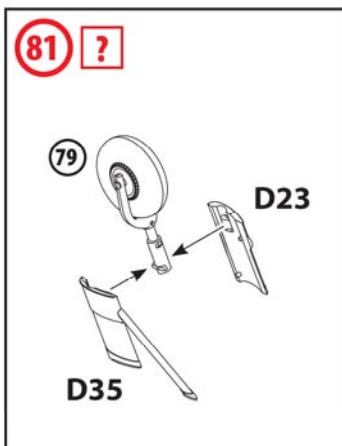
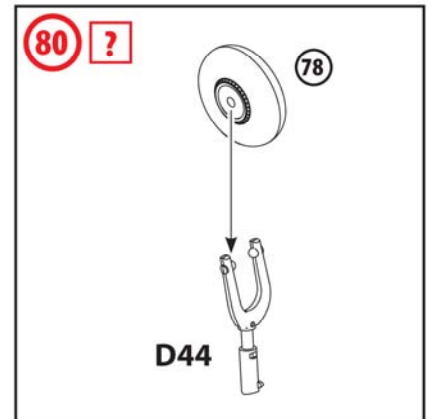
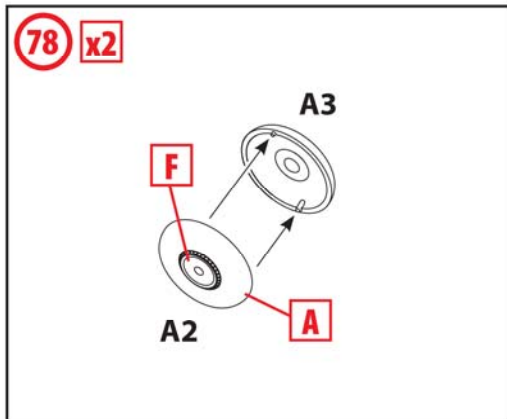
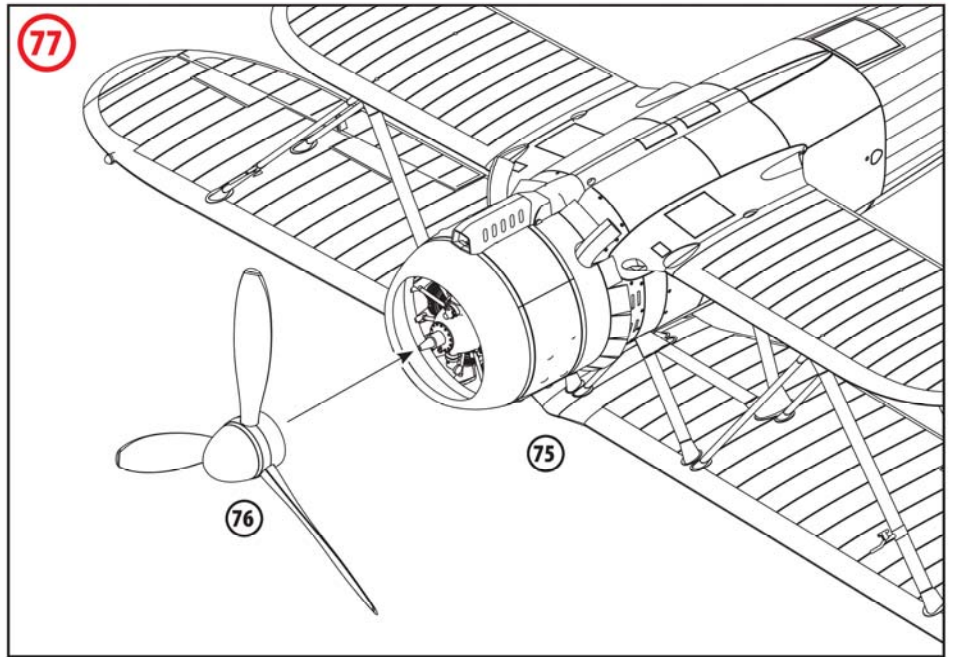
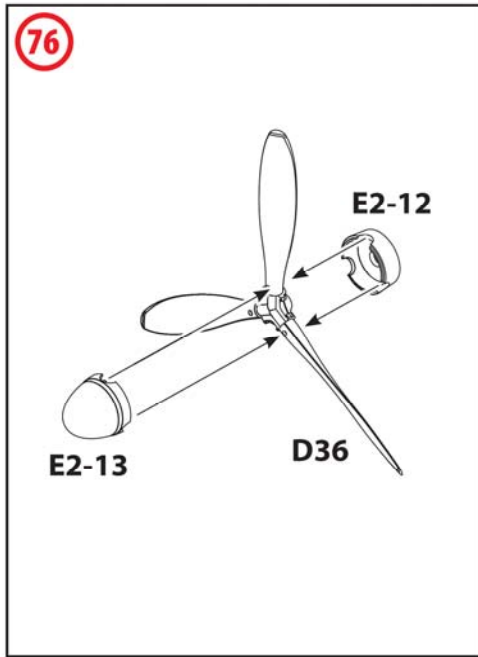

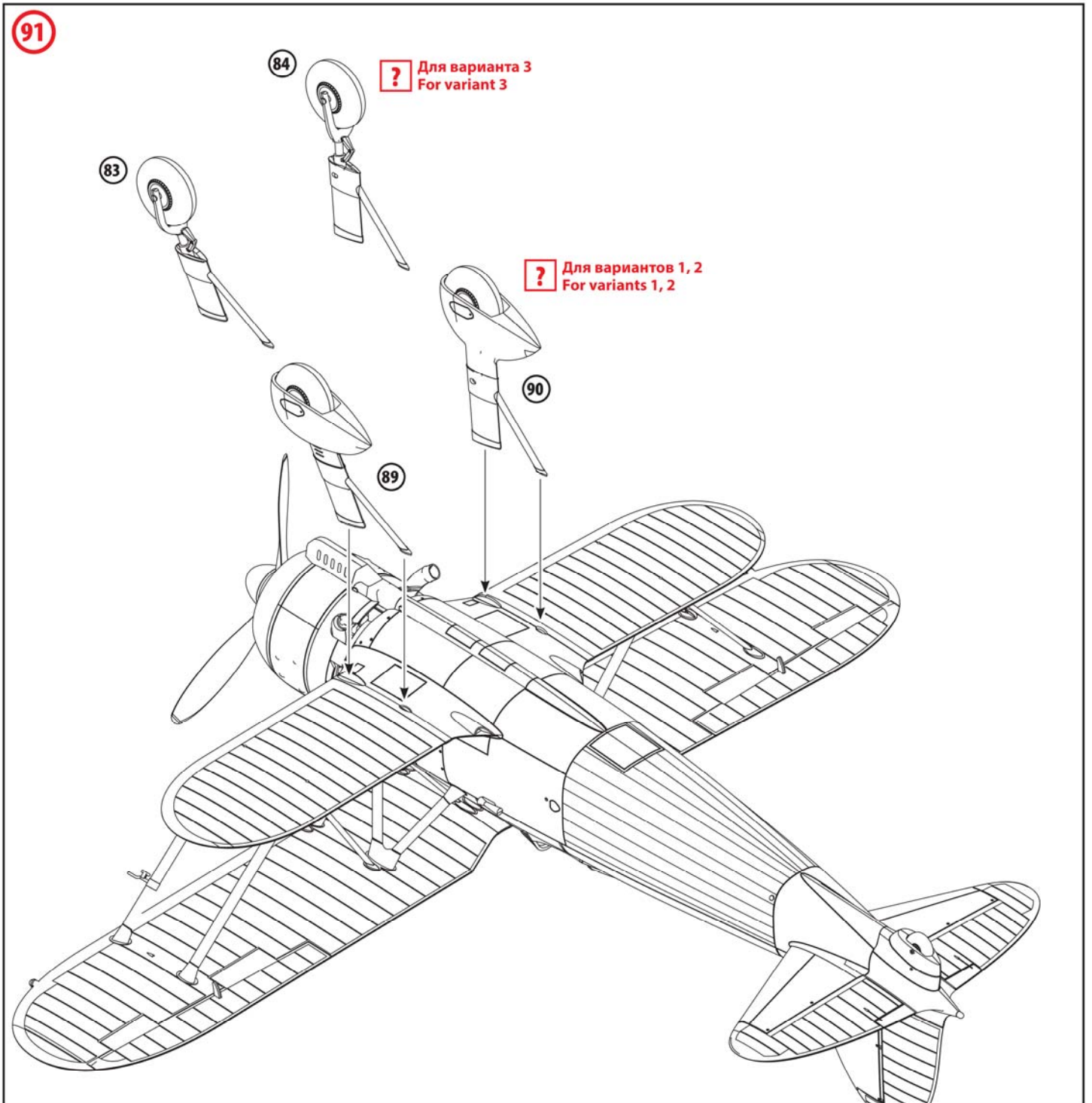
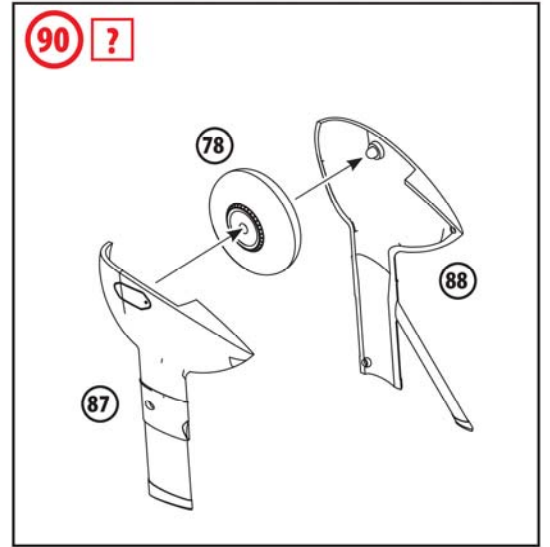
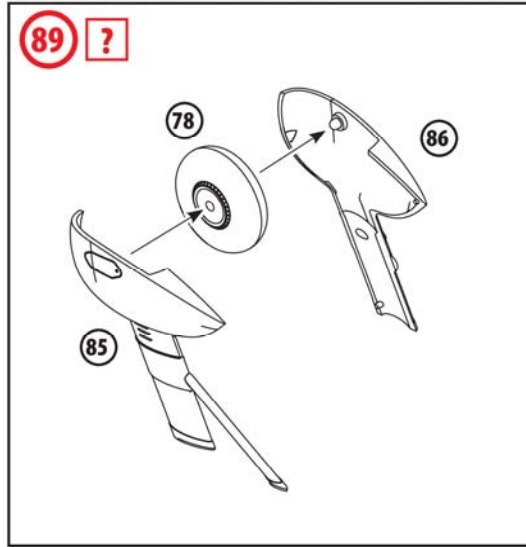
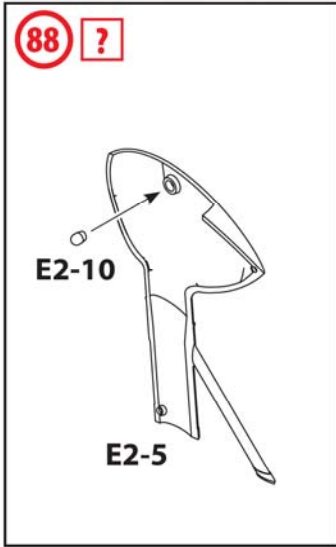

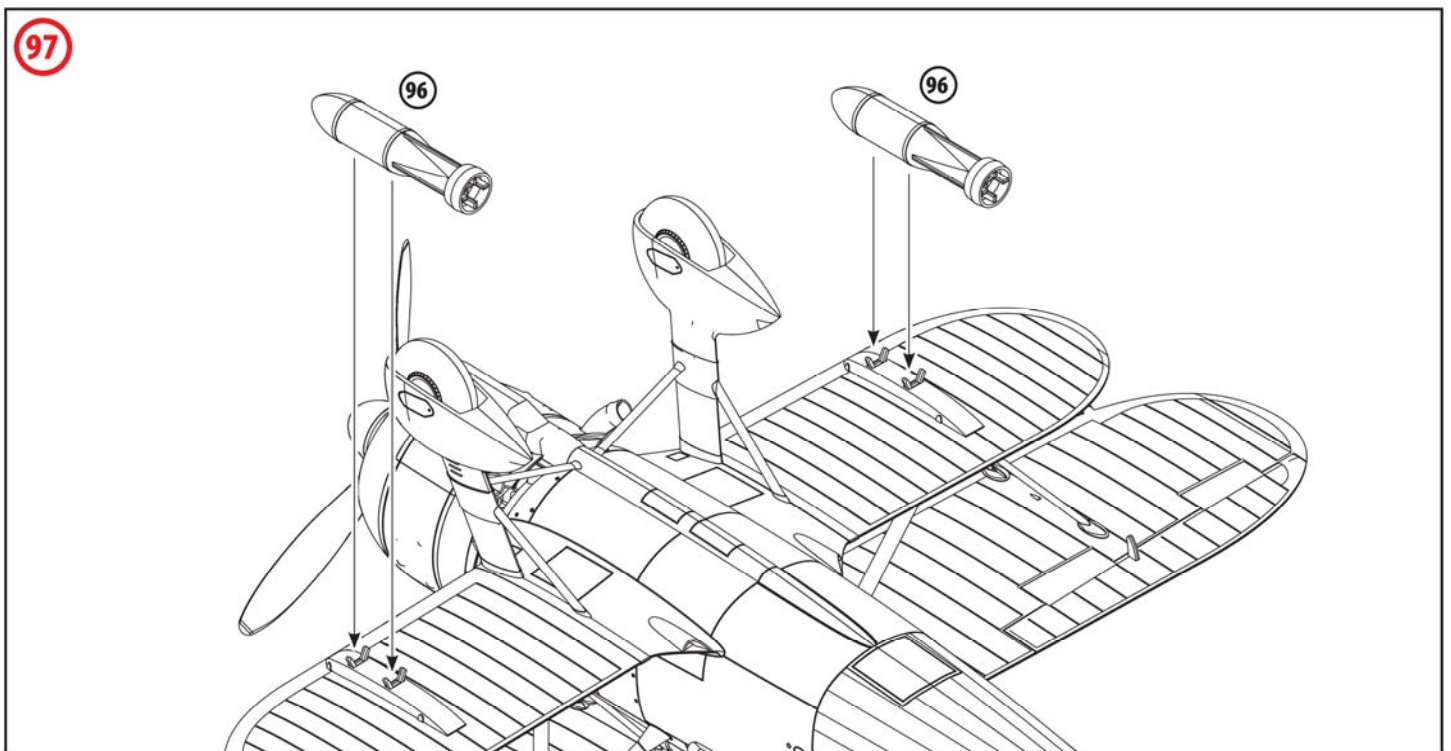
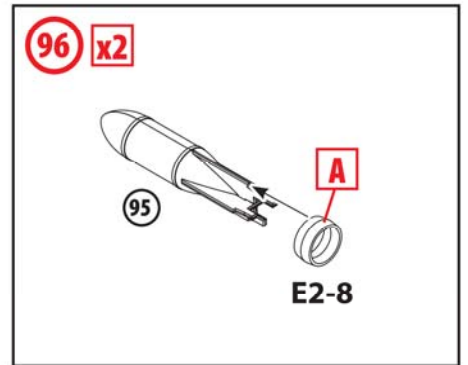
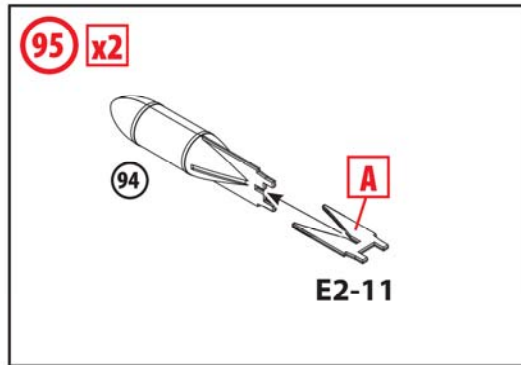
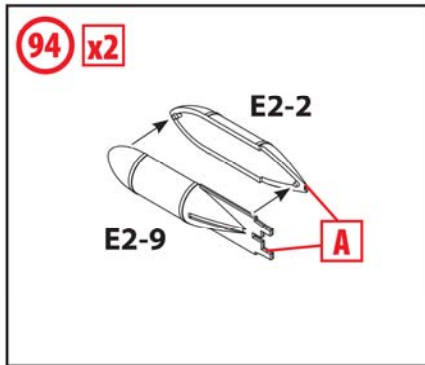
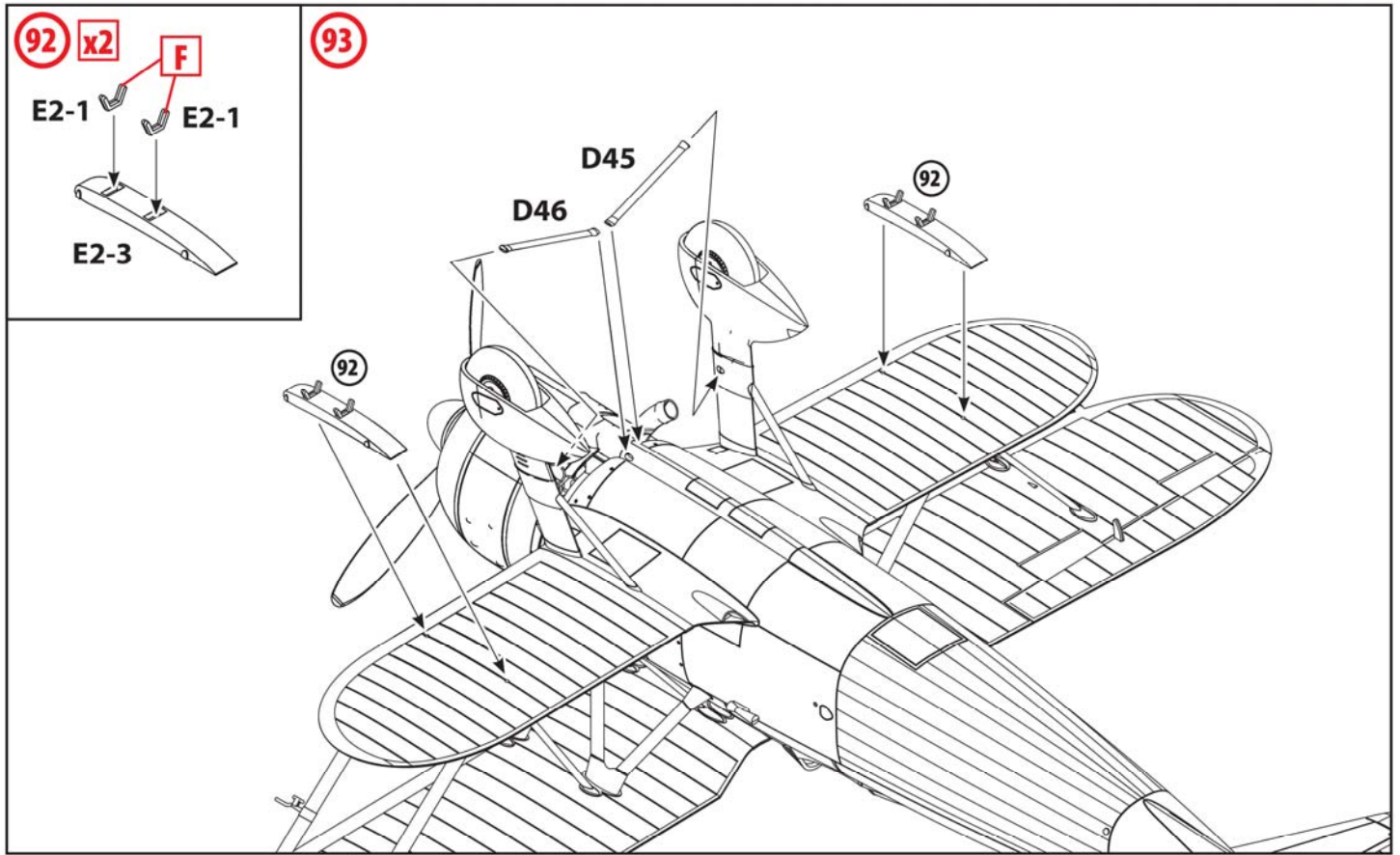

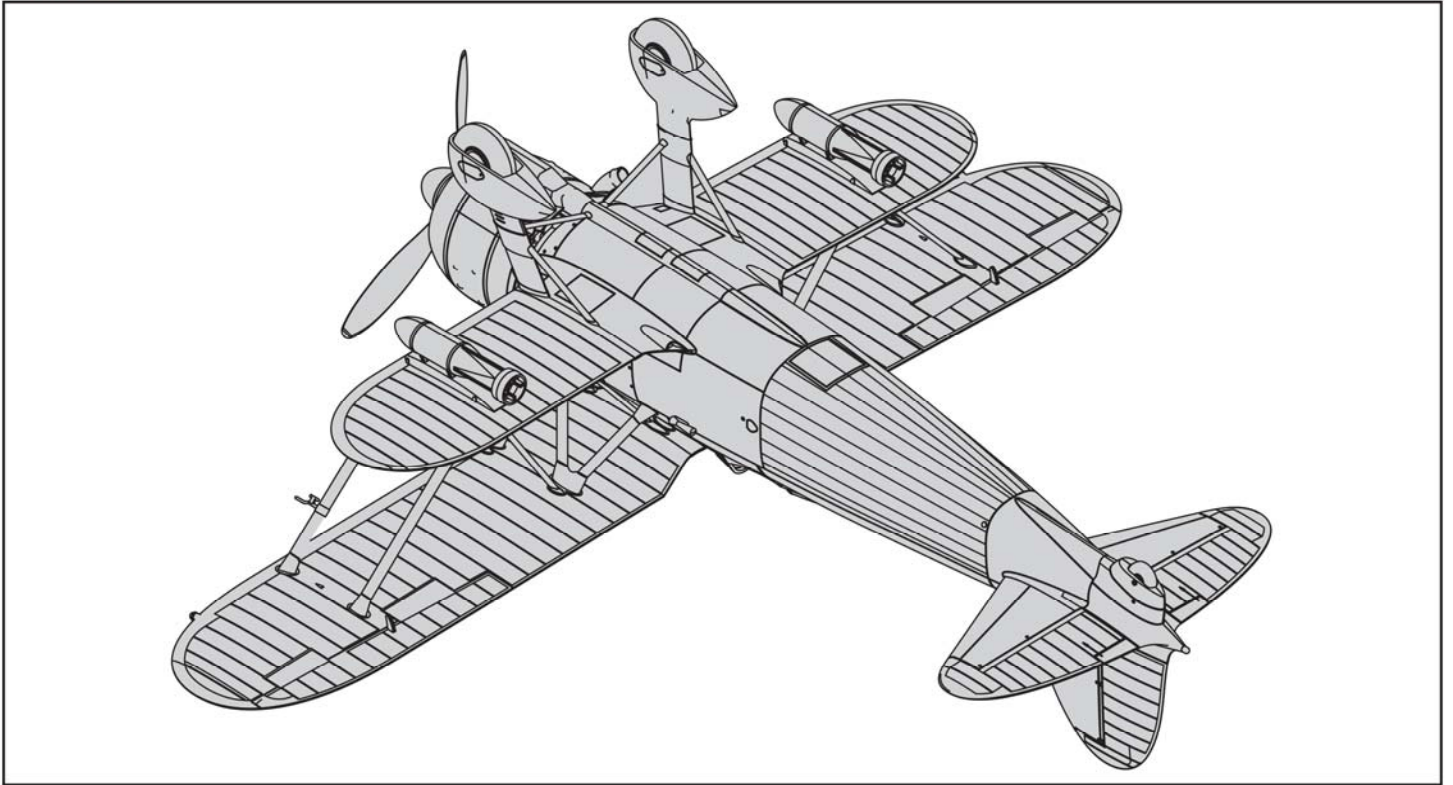

98 ✖

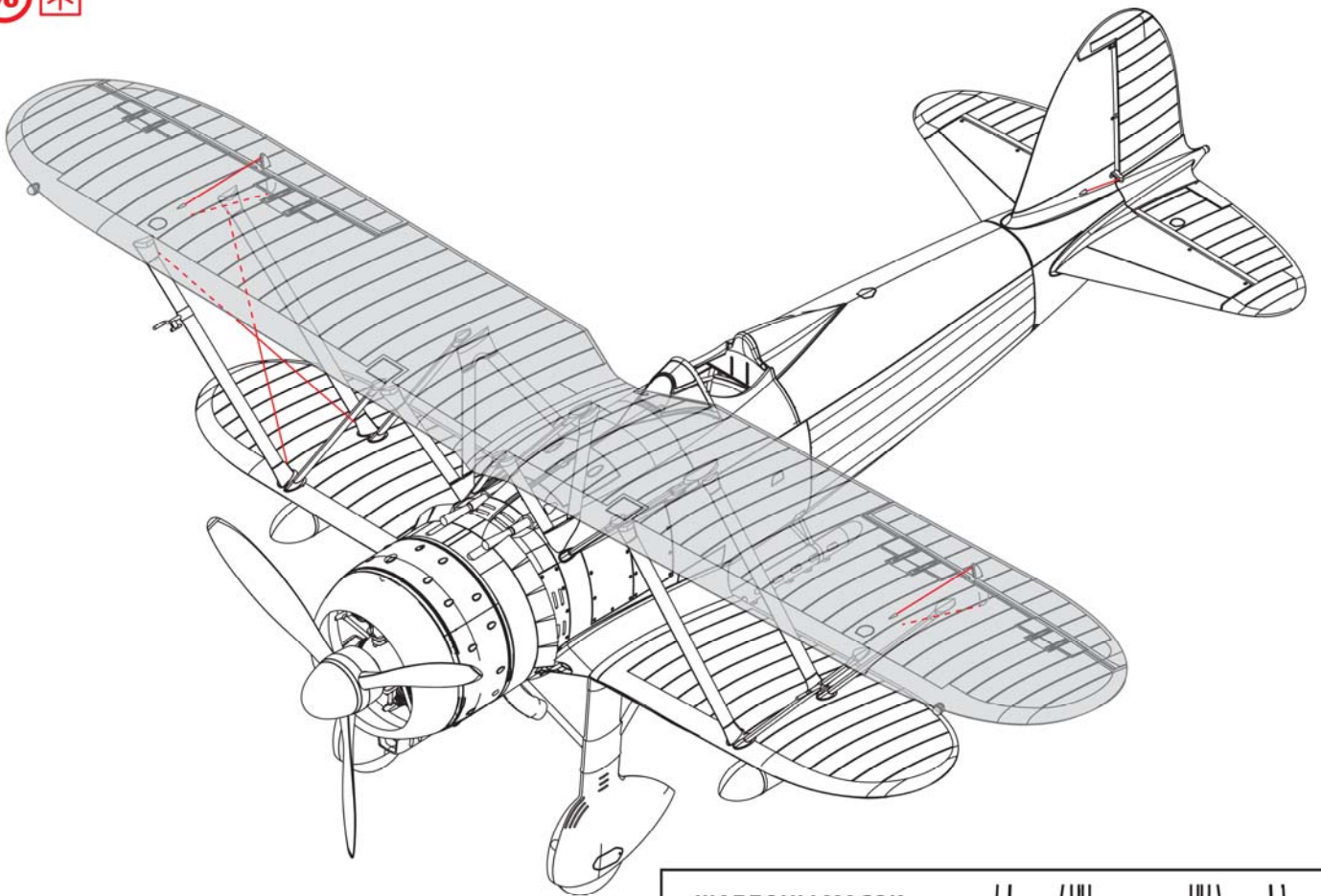

ШАБЛОНЫ МАСОК
MASK TEMPLATES

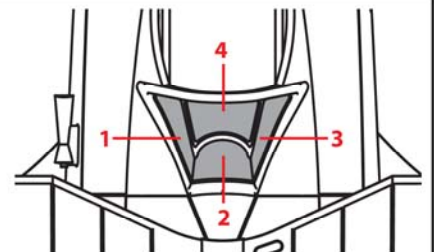
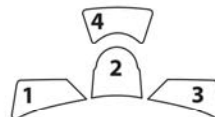

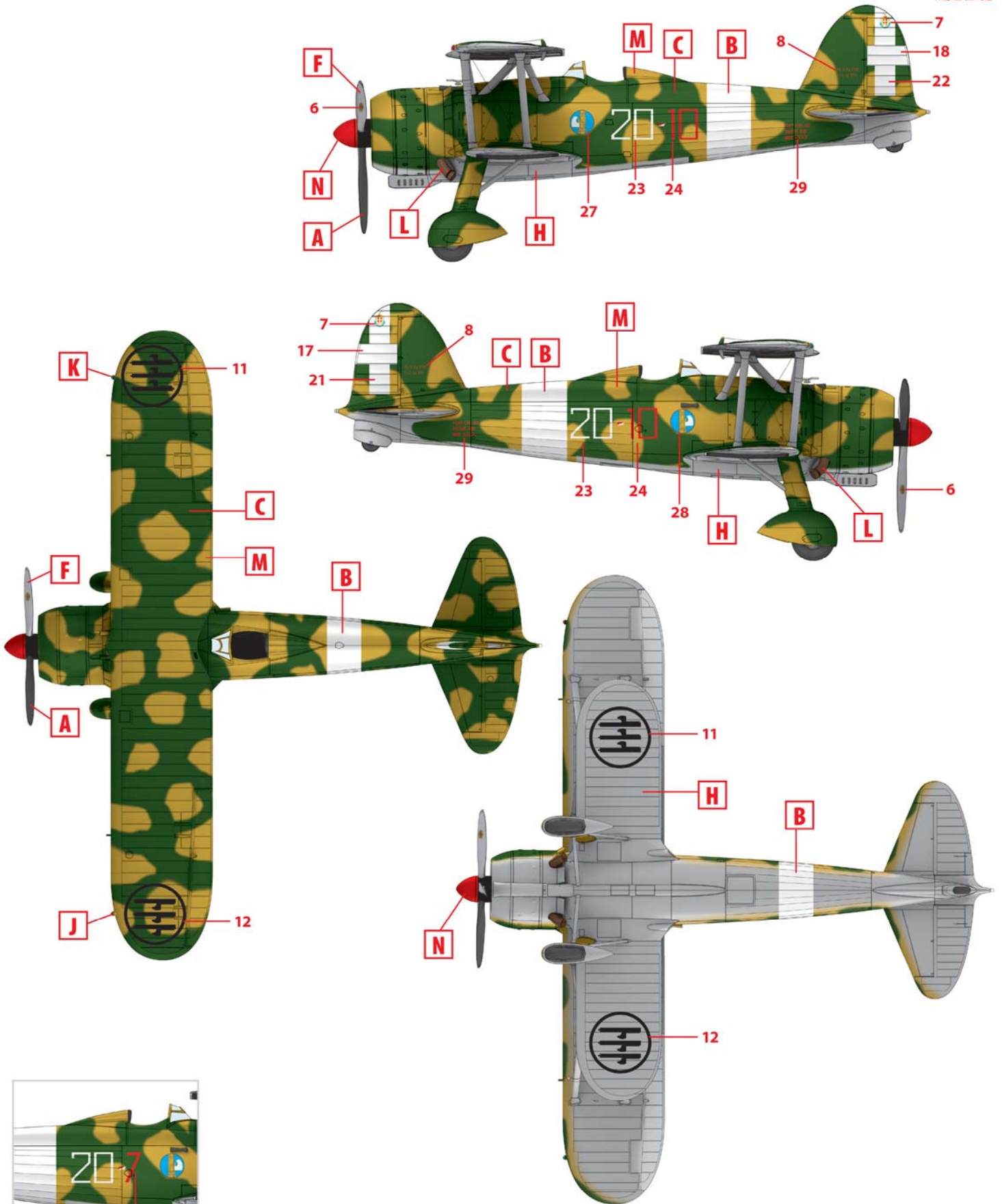

1. Fiat CR 42AS Falco 20. Эскадрилья, 46. Группа, 15. Штурм штурмовиков в Эль-Адеме (Ливия, Северная Африка) 1942 г.

Fiat CR 42AS Falco 20. Squadriglia, 46. Gruppo, 15. Stormo Assalto in El Adem (Libya, North Africa) 1942

2. Fiat CR 42AS Falco 20. Эскадрилья, 46. Группа, 15. Штурм штурмовиков в Эль-Адеме (Ливия, Северная Африка) 1942 г.

Fiat CR 42AS Falco 20. Squadriglia, 46. Gruppo, 15. Stormo Assalto in El Adem (Libya, North Africa) 1942

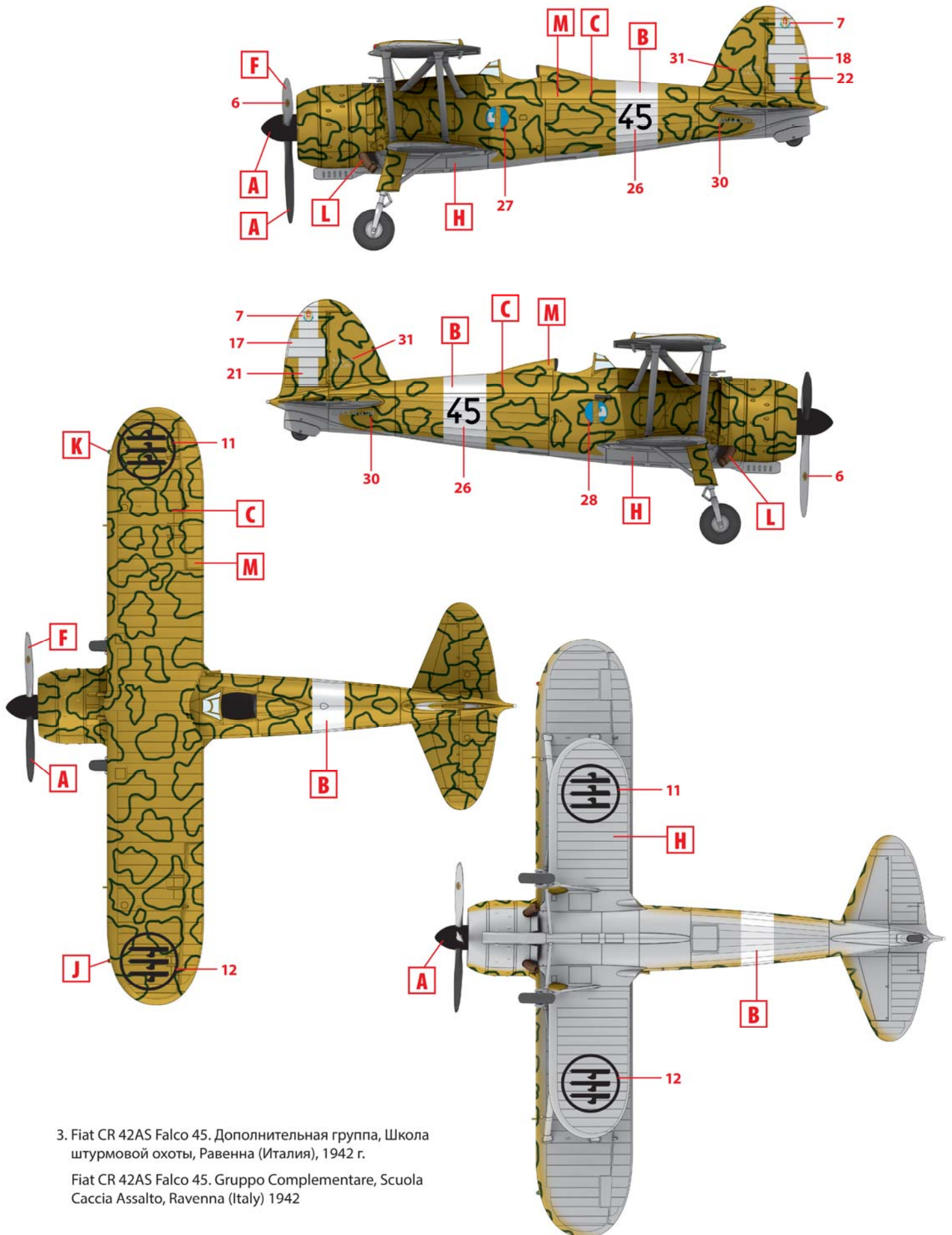

3. Fiat CR 42AS Falco 45. Дополнительная группа, Школа штурмовой охоты, Равенна (Италия), 1942 г.

Fiat CR 42AS Falco 45. Gruppo Complementare, Scuola Caccia Assalto, Ravenna (Italy) 1942