

GERMANY V1 MISSILE LAUNCHER WITH E75 BODY

modelcollect

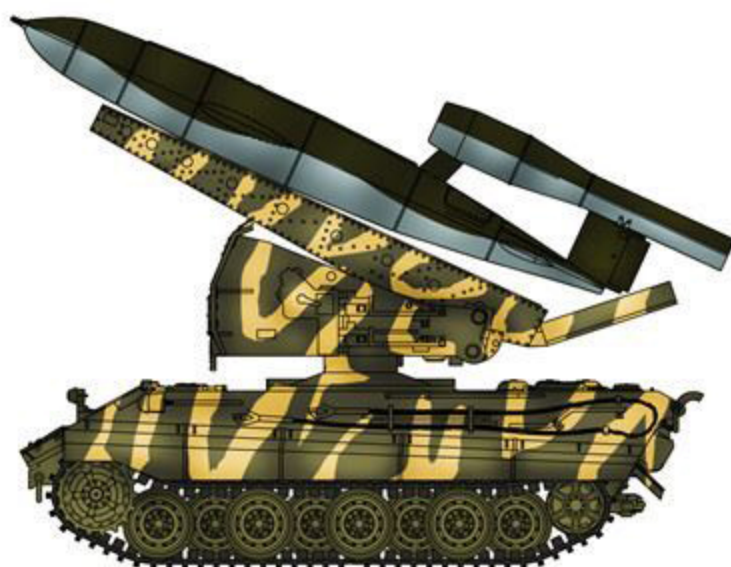

ITEM NO:UA72093

The E-50 Standardpanzer was intended as a standard medium tank, replacing the Panther and Tiger I and the conversions based on these tanks. The E-50 hull was to be longer than the Panther, in fact it was practically identical to the Königstiger (Tiger II) in overall dimensions except for the glacis plate layout. Compared to these earlier designs however, the amount of drilling and machining involved in producing these Standardpanzer was reduced drastically, which would have made them quicker, easier and cheaper to produce, as would the proposed conical spring system, replacing their predecessors' torsion bar system which required a special steel alloy.

Other sources show that a variant of the narrow-mantlet 'Schmalturm' turret designed for the Panther Ausf. F would have been used, coupled with a variant of the 88 mm L/71 gun.

As indicated by its name, the weight of the E-50 would fall between 50 and 75 tonnes. The engine was an improved Maybach HL234 which had 900 hp. Maximum speed was supposed to be 60 km/h.

●READ BEFORE ASSEMBLY

1. When you use glue or paint, do not near flame, and use in a well-ventiated room.
2. Take extra care in handling photo etch parts in order to avoid injury
3. When you take parts off the runner frame, use modeling scissors and trim excess plastic with a cutter or a file.
4. Glue and paint are not included.
5. This product is only suitable for experienced more than 14 years old.

●装配之前仔细阅读:

1. 勿於近火处使用胶水或油漆, 并打开窗户保持空气流通。
2. 取蚀刻片时应特别注意安全, 防止利边划伤手指。
3. 从胶架中取出部件时, 应用模型专用剪, 并用界刀或小锉除去多余的胶料。
4. 请使用塑料胶水和油漆, 模型内不含。
5. 本产品不适合14岁以下没有经验的模型爱好者。



SUPERGLUE

强力胶



WEIGHT

配重

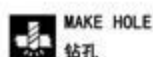

MAKE HOLE

钻孔

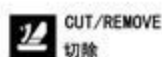

CUT/REMOVE

切除



BEND

弯曲



FILE/SAND

锉平



OPTION

选择

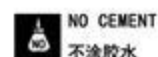

NO CEMENT

不涂胶水



DECAL

贴纸

DECAL APPLICATION

1. Cut off decal from sheet.
2. Dip the decal in tepid water 40° C for about 10 sec. and place on a clean cloth.
3. Hold the backing sheet edge and slide decal onto the model.
4. Move decal into position by wetting decal with finger.
5. Press decal gently down with a soft cloth until excess water and air bubbles are gone.

水贴纸的使用:

1. 从水贴纸上剪下印花。
2. 将印花放入温水中浸10秒, 然后放在干净布上。
3. 拿着印花纸板将印花移到模型上。
4. 手指蘸水将印花移到适当的位置。
5. 用软布轻压印花直至不干, 气泡消失。

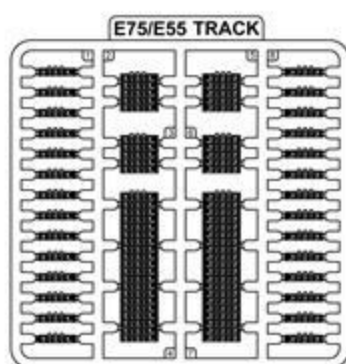
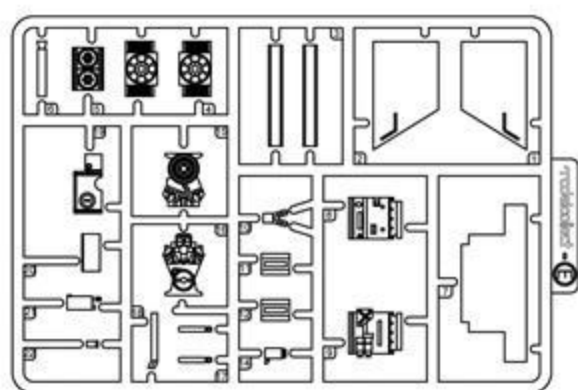
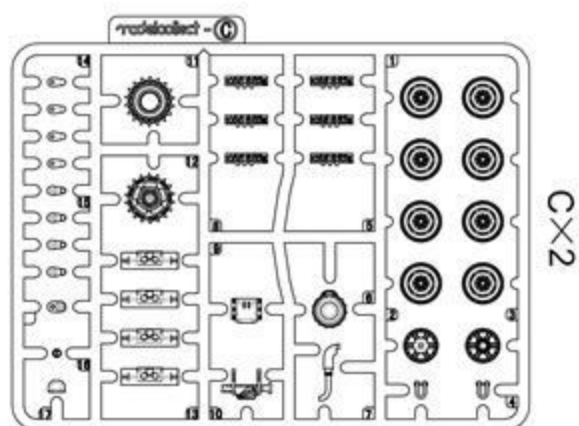
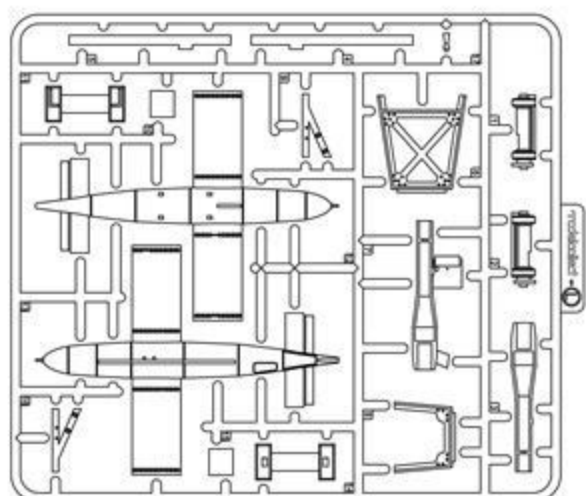
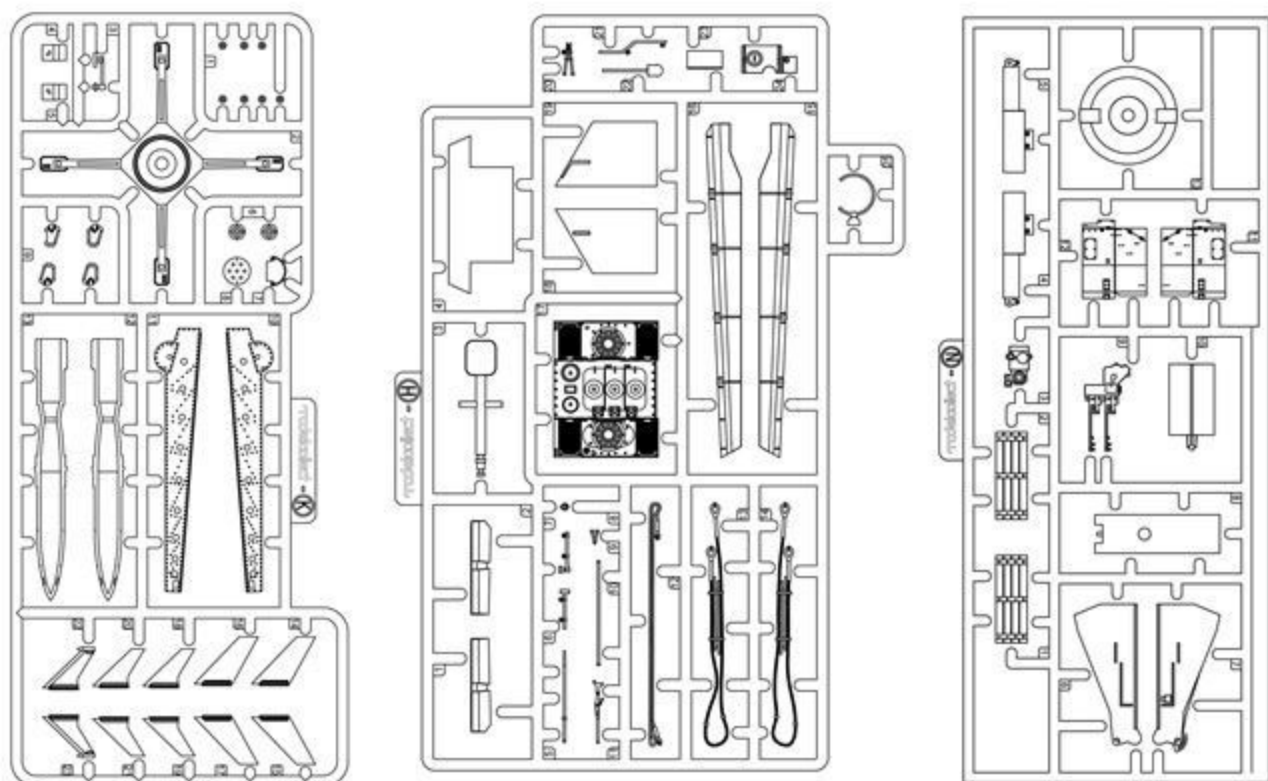

× 2

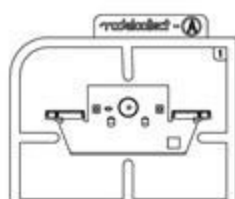
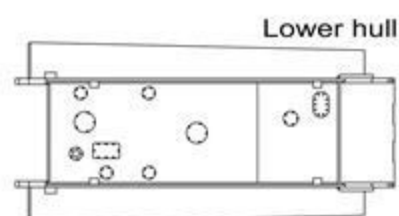
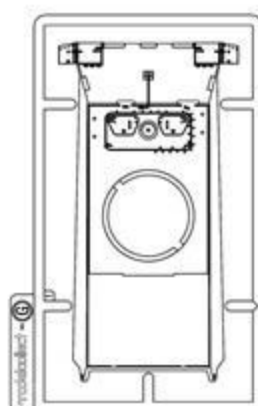

Decal

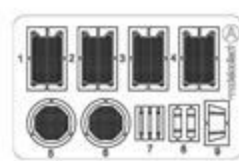

PE

1 导弹组装1
Attaching missile 1

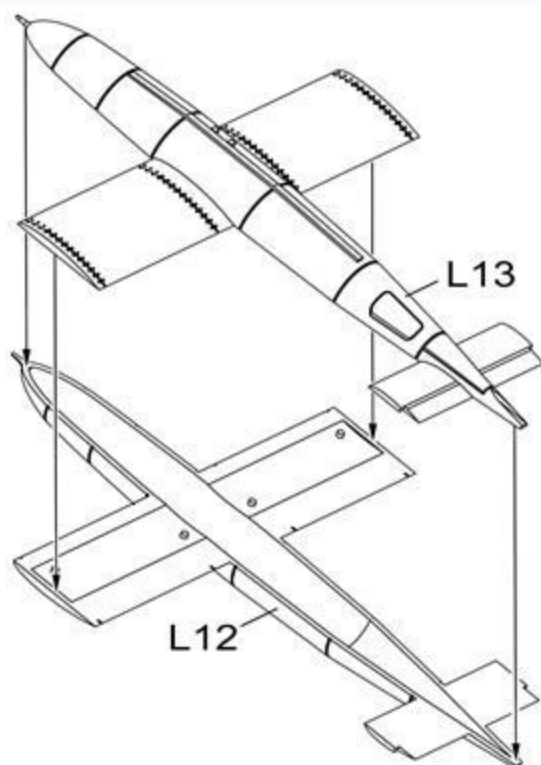

2 导弹组装2
Attaching missile 2

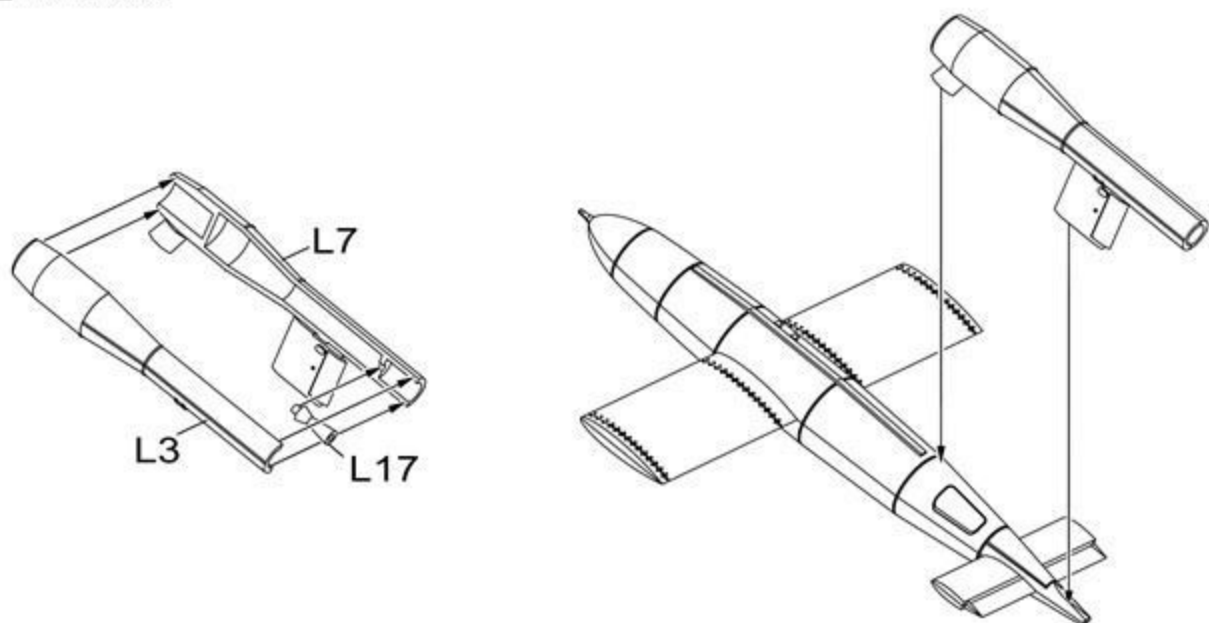

3 发射架组装1
Attaching the launcher 1

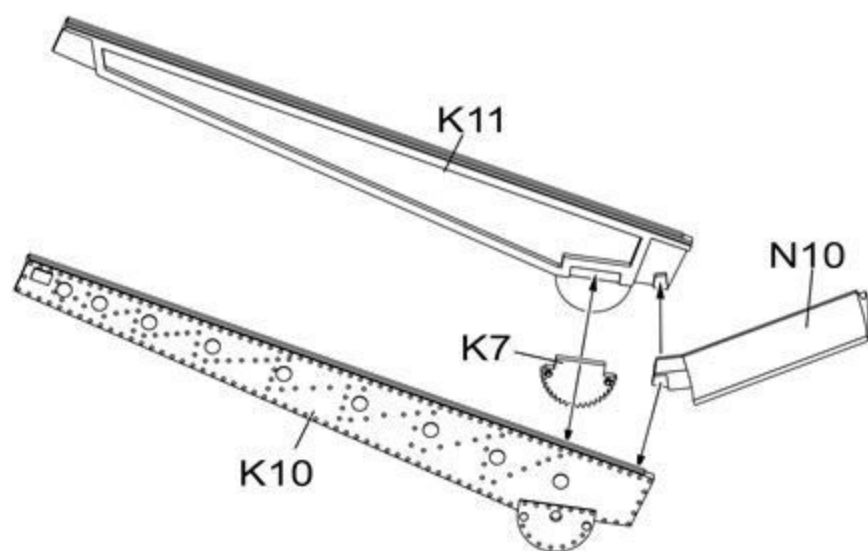

4 发射架组装2
Attaching the launcher 2

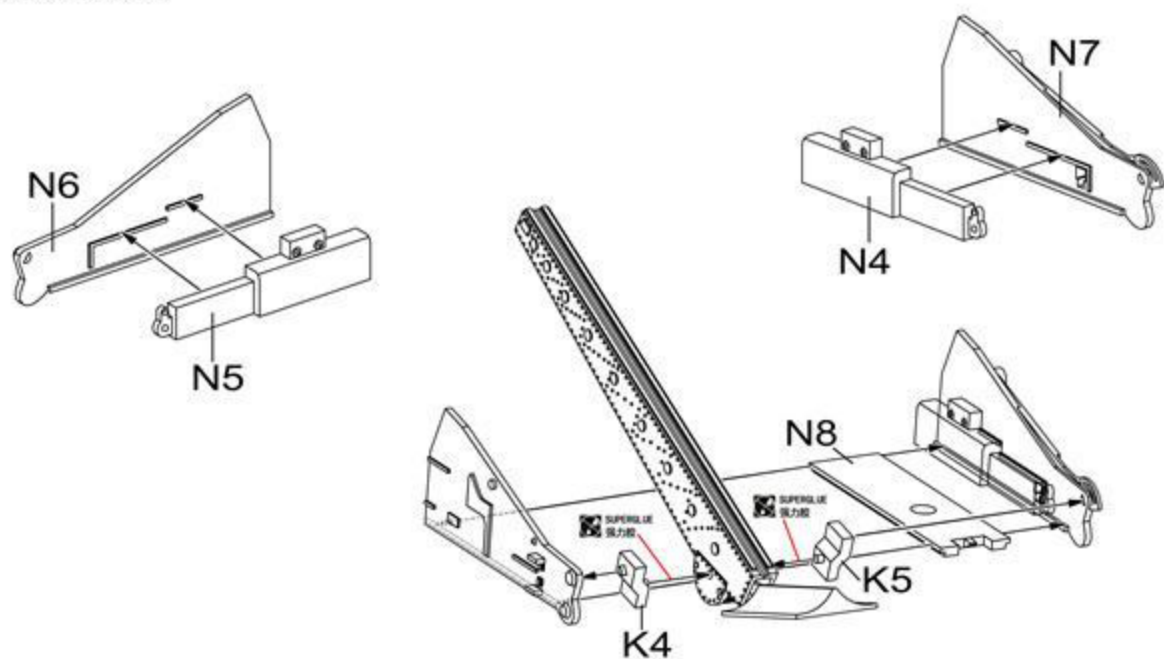

5 发射架组装3
Attaching the launcher 3

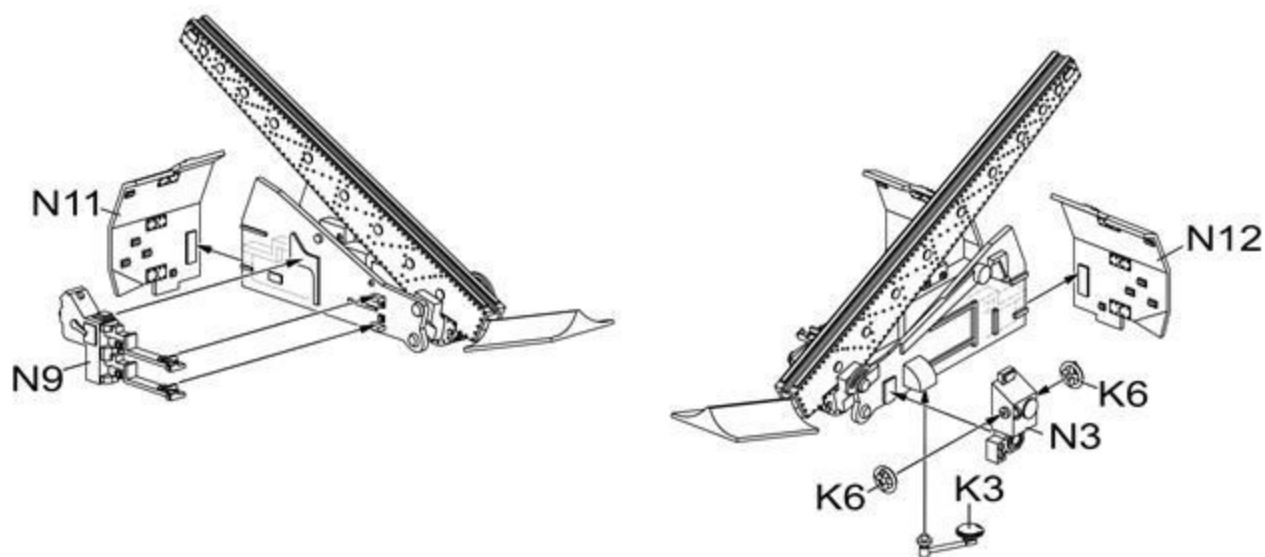

6 导弹、发射架组装
Attaching the missile and launcher

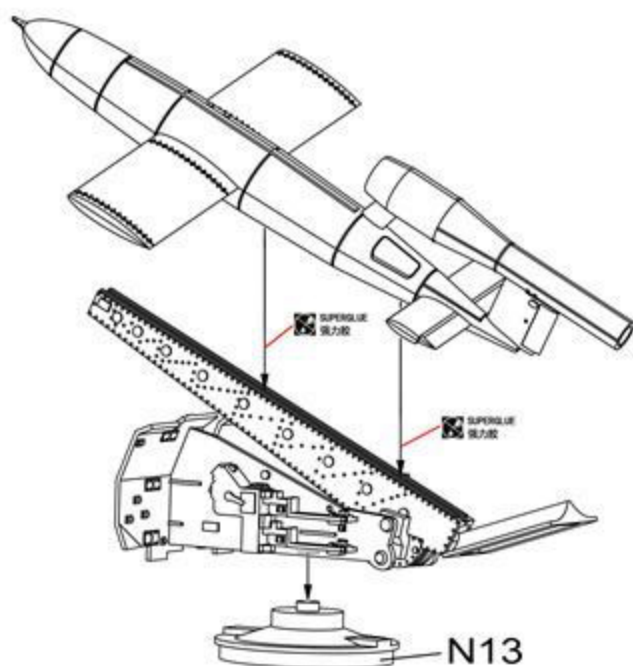

7 组装车体1
Attaching hull 1

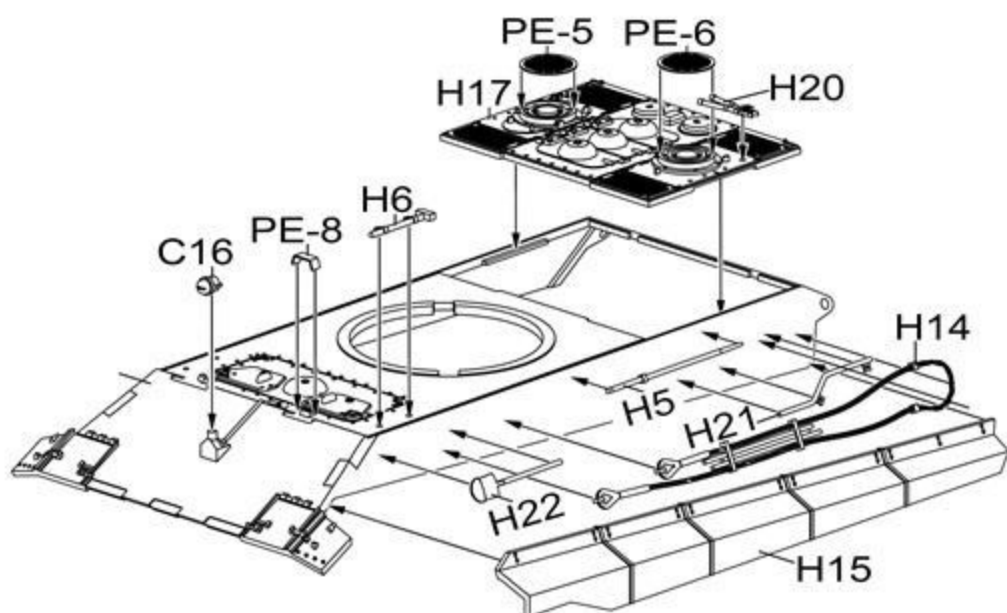

8 组装车体2
Attaching hull 2

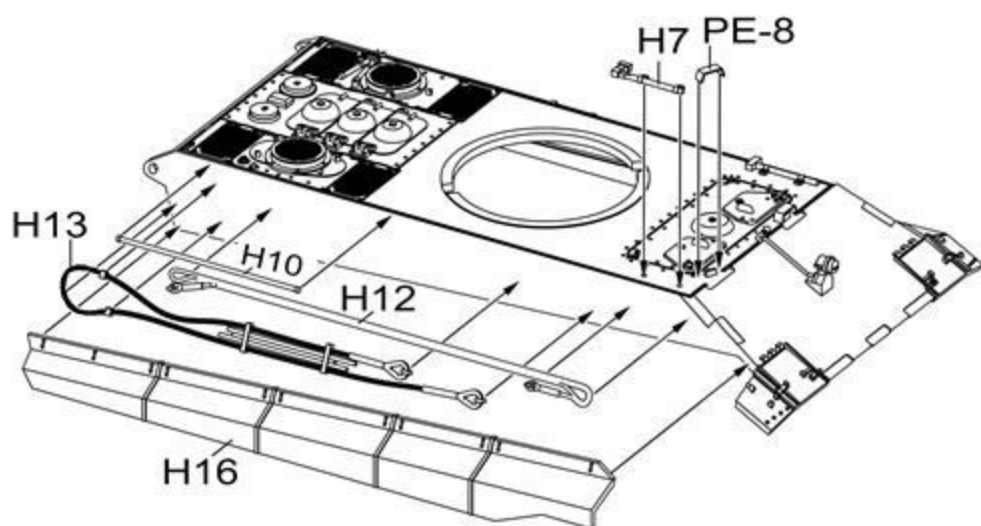

9 组装车轮和悬挂1
Attaching wheels and suspension 1

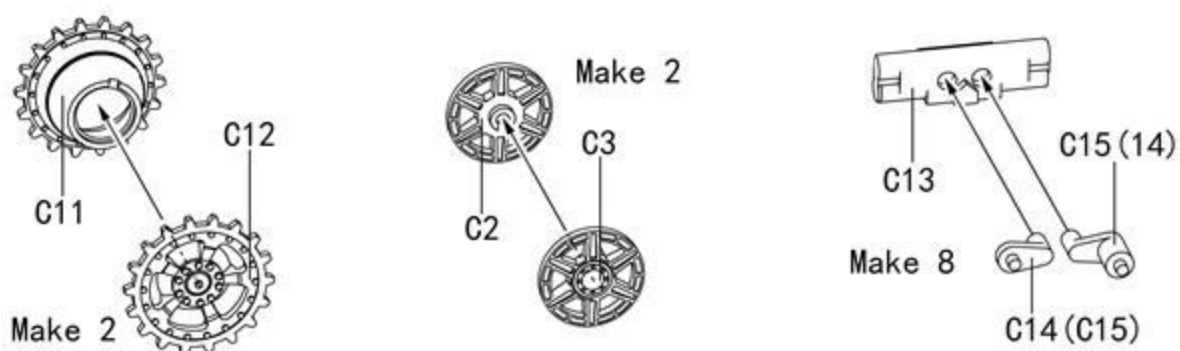

10 组装车轮和悬挂2
Attaching wheels and suspension 2

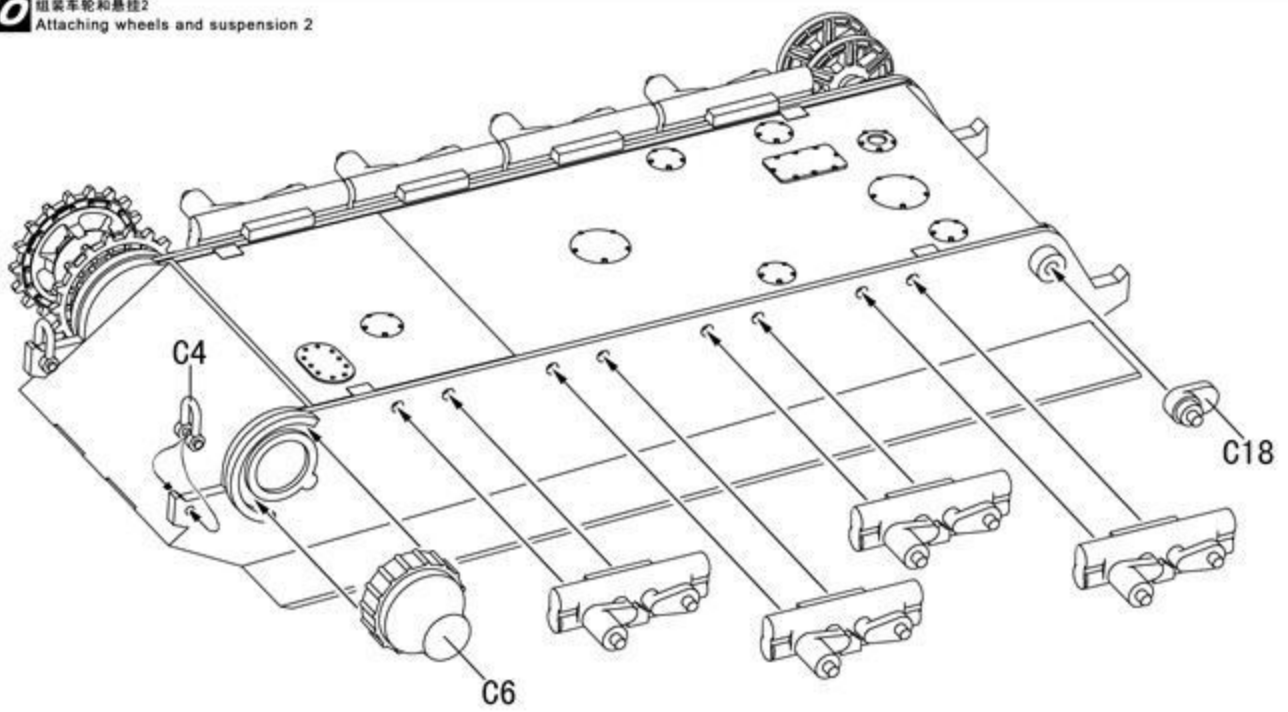

11 组装车轮和悬挂3
Attaching wheels and suspension 3

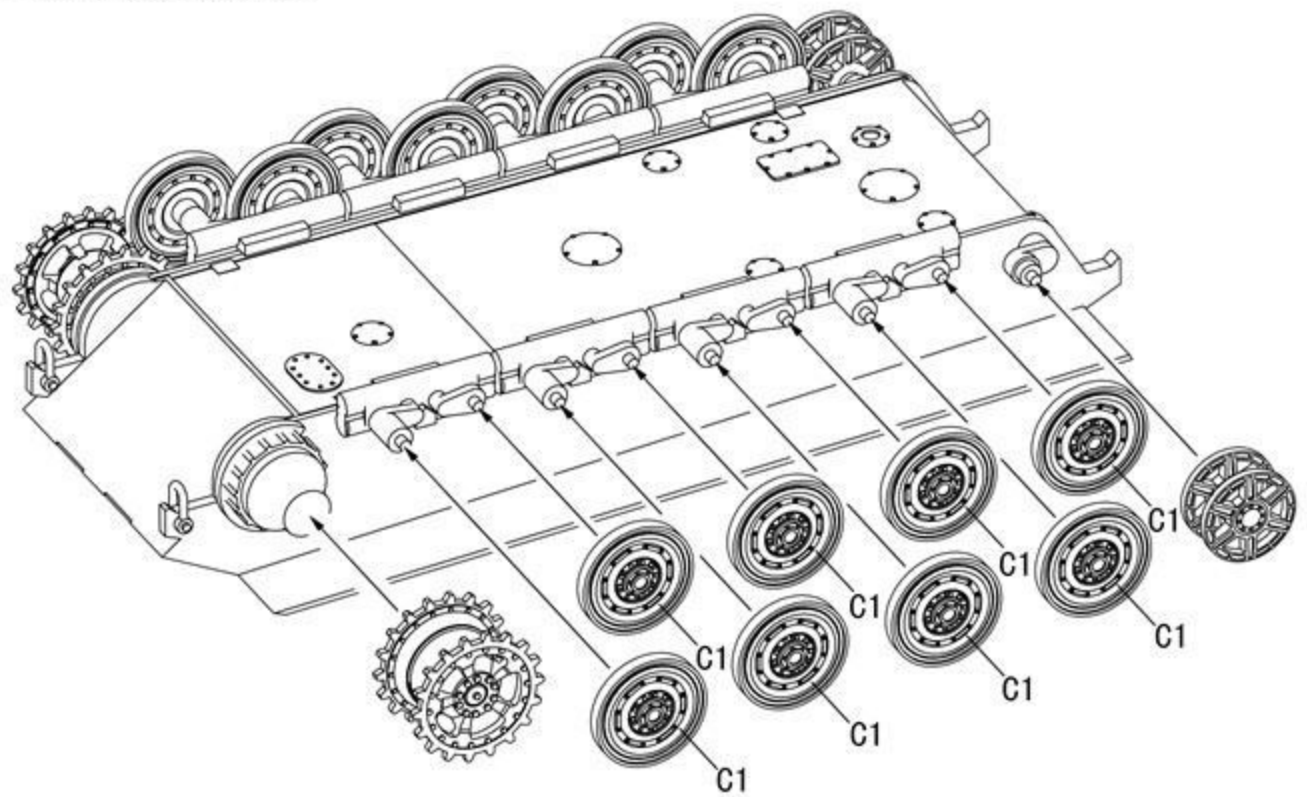

12 组装车尾
Attaching hull

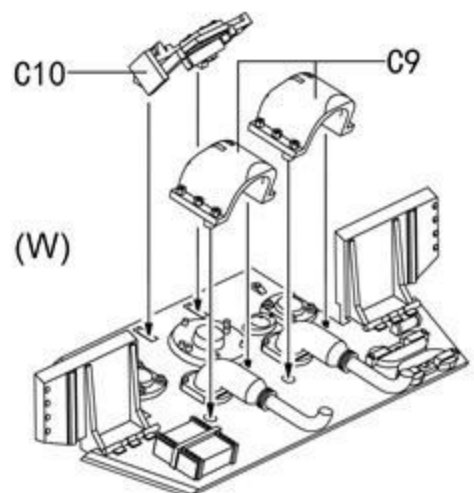
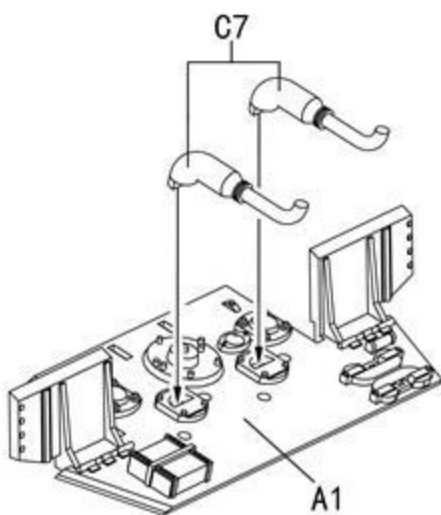

13 组装拼接履带
Attaching tracks

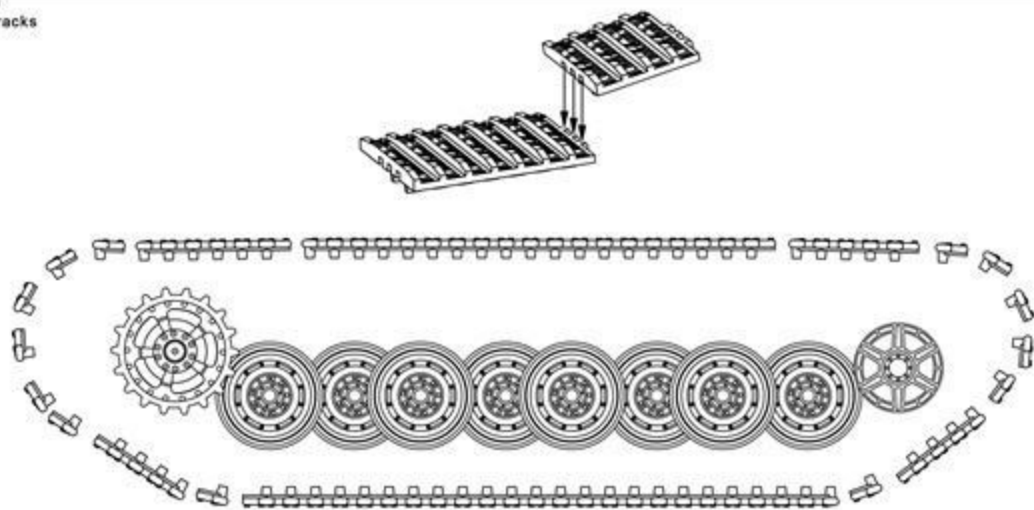

14 组装发动机舱 1
Attaching engine 1

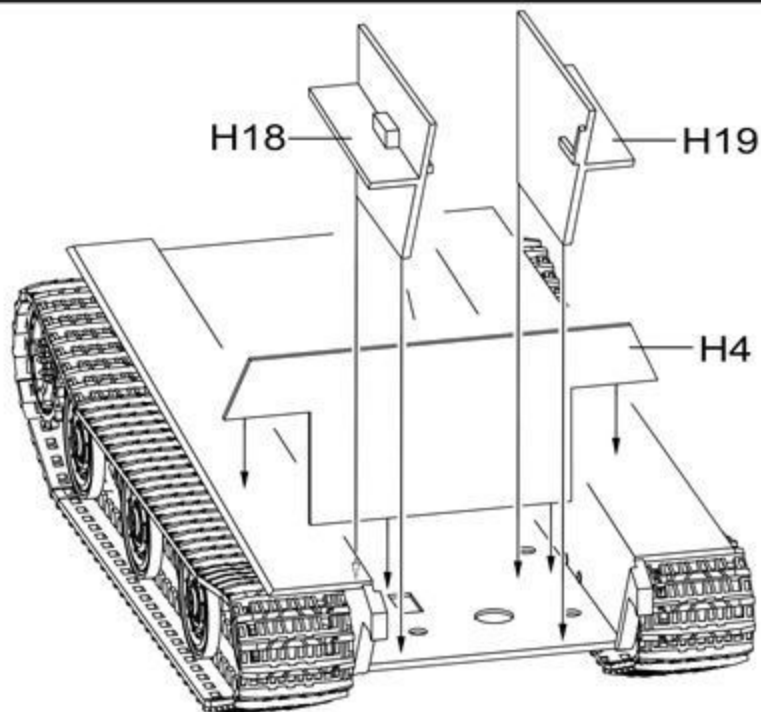

15 组装发动机舱 2
Attaching engine 2

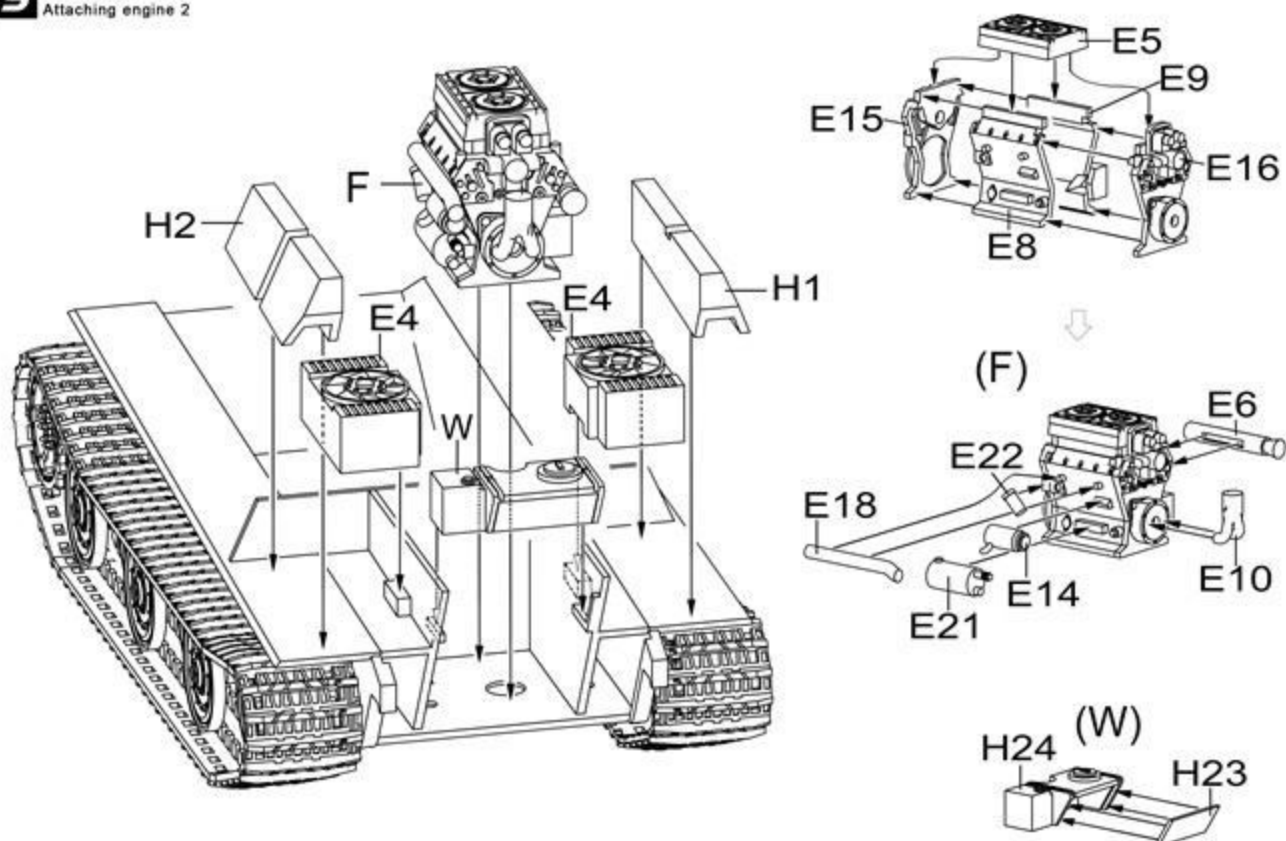

16 组装车体
Attaching hull

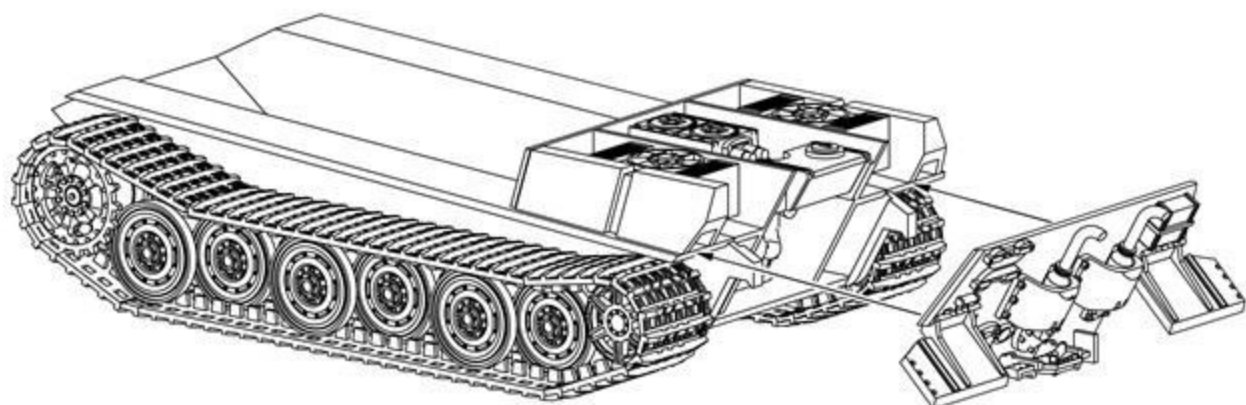

17 组装炮塔和车体
Attaching turret and hull

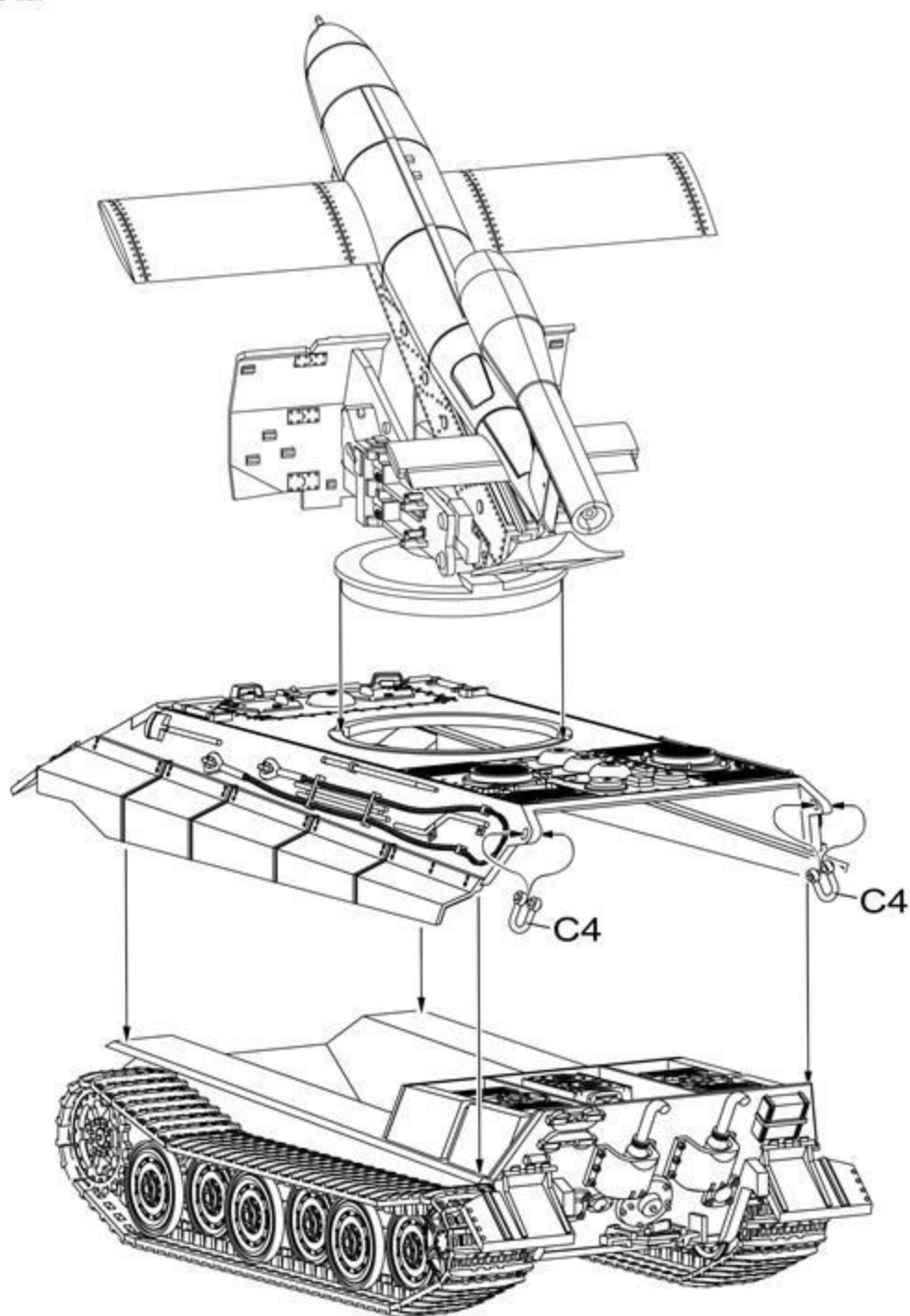

GERMANY V1 MISSILE LAUNCHER WITH E75 BODY

modelcollect

A.MIG 011 RAL 7028 DUNKELGELB AUS 44 DG I	A.MIG 003 RAL 6011 RESEDAGRÜN	A.MIG 008 RAL 7021 DUNKELGRAU	A.MIG 035 DARK TRACKS	A.MIG 037 NEW WOOD	A.MIG 911 GREY SHINE
A.MIG 014 RAL 8012 ROTBRAUN	A.MIG 216 RLM 66 SCHWARTZGRAU	A.MIG 042 OLD RUST	A.MIG 230 82 GREEN	A.MIG 063 PALE GREY	

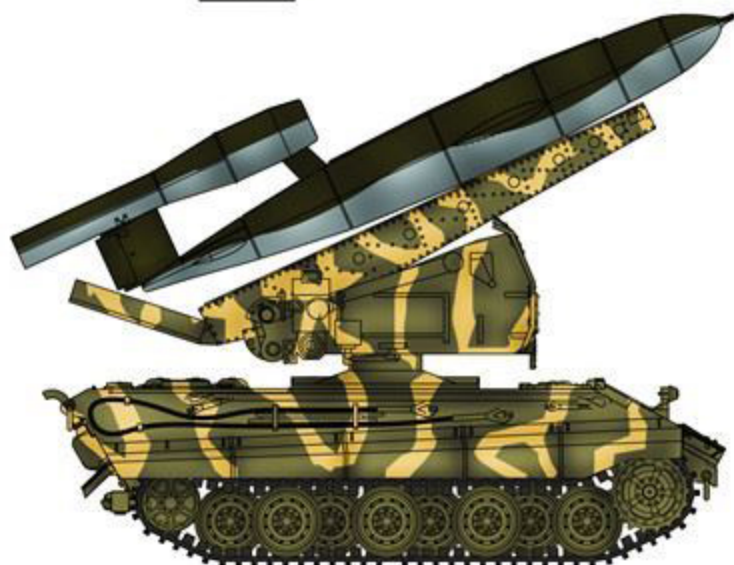
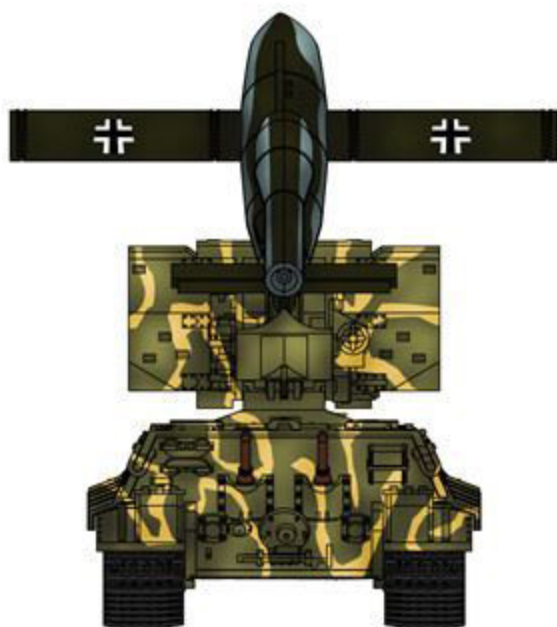
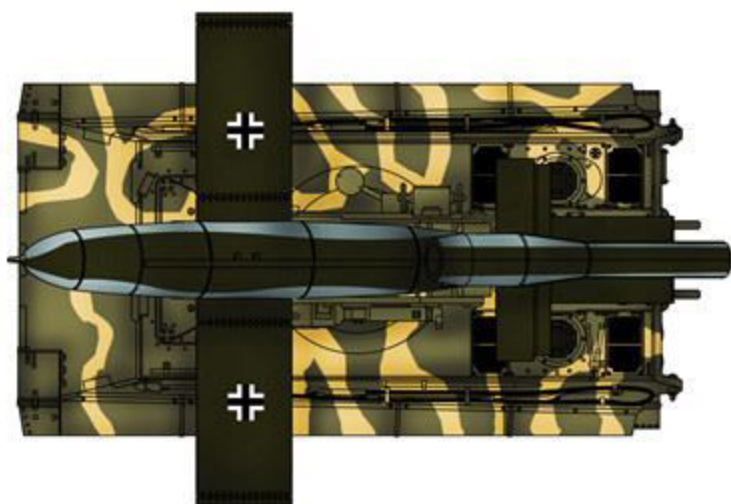
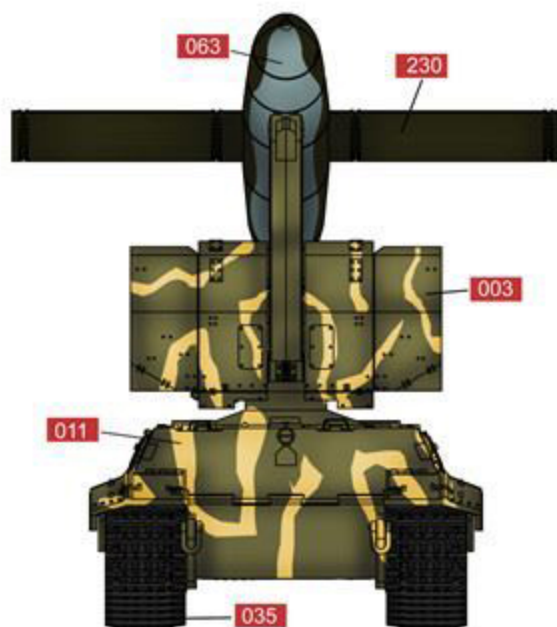
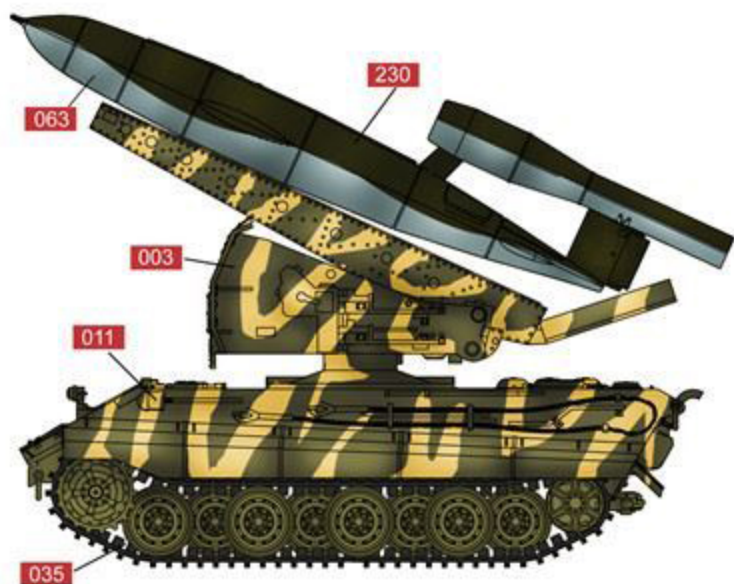

MODEL COLLECT

Germany V1 MISSILE LAUNCHER WITH E75 BODY UA72093

Color info and profiles by



GERMANY V1 MISSILE LAUNCHER WITH E75 BODY

modelcollect

A.MIG 011 RAL 7028 DUNKELGELB AUS 44 DG I	A.MIG 003 RAL 9011 RESEDAGRÜN	A.MIG 008 RAL 7021 DUNKELGRAU	A.MIG 035 DARK TRACKS	A.MIG 037 NEW WOOD	A.MIG 911 GREY SHINE
A.MIG 014 RAL 8012 ROTBRAUN	A.MIG 218 RLM 66 SCHWARTZGRAU	A.MIG 057 Yellow Grey	A.MIG 230 R2 GREEN	A.MIG 063 PALE GREY	

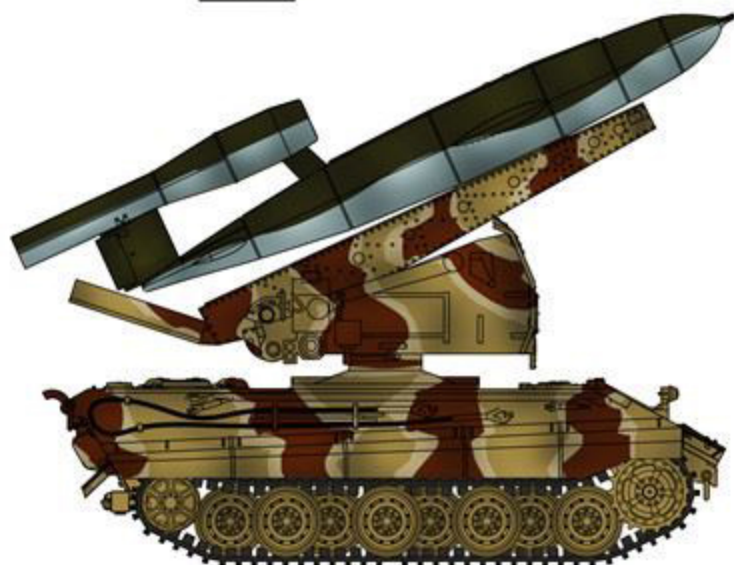
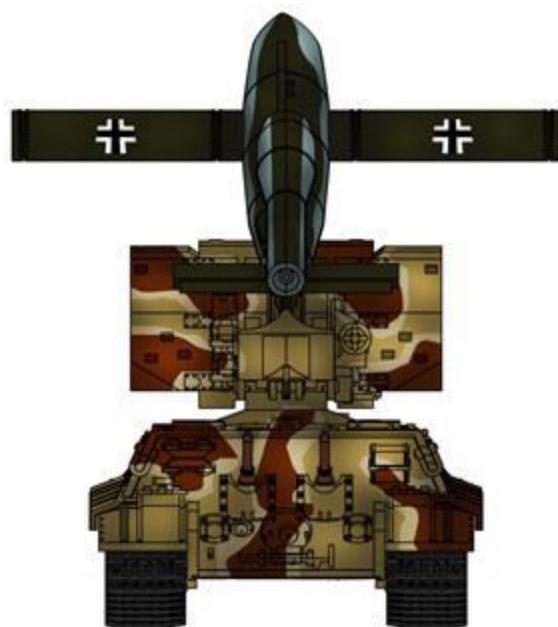
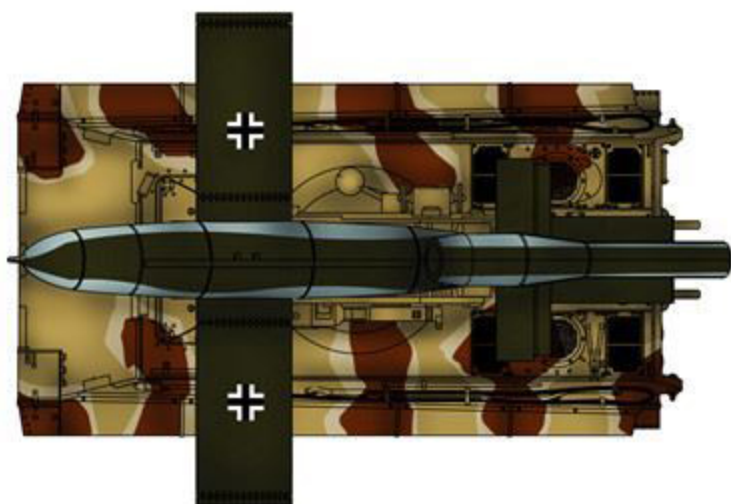
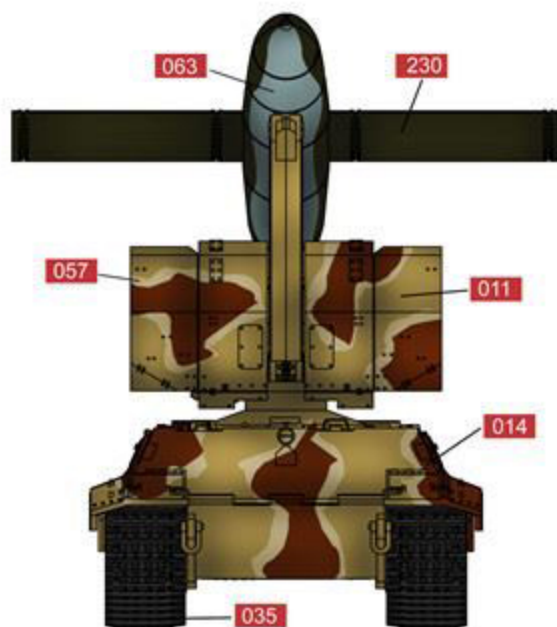
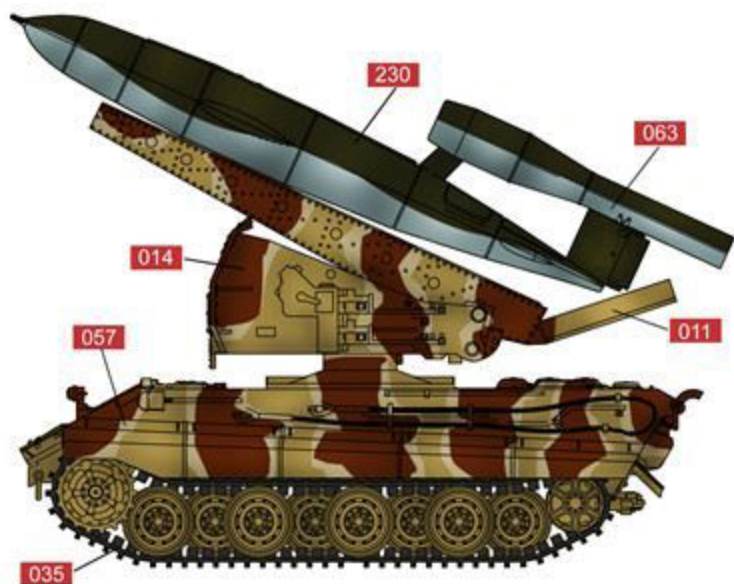

MODEL COLLECT

Germany V1 MISSILE LAUNCHER WITH E75 BODY UA72093

Color info and profiles by

