

U.S.A.F B-2A SPIRIT

STEALTH BOMBER 美国空军B-2A“幽灵”隐形轰炸机



搜模閣

UA72201
1:72
SCALE

modelcollect

U.S.A.F B-2A SPIRIT STEALTH BOMBER



The Northrop (later Northrop Grumman) B-2 Spirit, also known as the Stealth Bomber, is an American heavy penetration strategic bomber, featuring low observable stealth technology designed for penetrating dense anti-aircraft defenses; it is a flying wing design with a crew of two. The bomber can deploy both conventional and thermonuclear weapons, such as eighty 500 lb (230 kg)-class (Mk 82) JDAM Global Positioning System-guided bombs, or sixteen 2,400 lb (1,100 kg) B83 nuclear bombs. The B-2 is the only acknowledged aircraft that can carry large air-to-surface standoff weapons in a stealth configuration.

Development originally started under the "Advanced Technology Bomber" (ATB) project during the Carter administration; its expected performance was one of his reasons for the cancellation of the supersonic B-1A bomber. The ATB project continued during the Reagan administration, but worries about delays in its introduction led to the reinstatement of the B-1 program, as well. Program costs rose throughout development. Designed and manufactured by Northrop, later Northrop Grumman, the cost of each aircraft averaged US\$737 million (in 1997 dollars). Total procurement costs averaged \$929 million per aircraft, which includes spare parts, equipment, retrofitting, and software support. The total program cost including development, engineering and testing, averaged \$2.1 billion per aircraft in 1997.

Because of its considerable capital and operating costs, the project was controversial in the U.S. Congress and among the Joint Chiefs of Staff. The winding-down of the Cold War in the latter portion of the 1980s dramatically reduced the need for the aircraft, which was designed with the intention of penetrating Soviet airspace and attacking high-value targets. During the late 1980s and 1990s, Congress slashed plans to purchase 132 bombers to 21. In 2008, a B-2 was destroyed in a crash shortly after takeoff, though the crew ejected safely. There are 20 B-2s in service with the United States Air Force, which plans to operate the B-2 until 2058.

The B-2 is capable of all-altitude attack missions up to 50,000 feet (15,000 m), with a range of more than 6,000 nautical miles (6,900 mi; 11,000 km) on internal fuel and over 10,000 nautical miles (12,000 mi; 19,000 km) with one midair refueling. It entered service in 1997 as the second aircraft designed to have advanced stealth technology after the Lockheed F-117 Nighthawk attack aircraft. Though designed originally as primarily a nuclear bomber, the B-2 was first used in combat, dropping conventional, non-nuclear ordnance in the Kosovo War in 1999. It later served in Iraq, Afghanistan, and Libya.

General characteristics

Crew: 2: pilot (left seat) and mission commander (right seat)
 Length: 69 ft (21.0 m)
 Wingspan: 172 ft (52.4 m)
 Height: 17 ft (5.18 m)
 Wing area: 5,140 ft² (478 m²)
 Empty weight: 158,000 lb (71,700 kg)
 Loaded weight: 336,500 lb (152,200 kg)
 Max. takeoff weight: 376,000 lb (170,600 kg)
 Fuel Capacity: 167,000 pounds (75,750 kg)
 Powerplant: 4 × General Electric F118-GE-100 non-afterburning turbofans, 17,300 lbf (77 kN) each

Manufacturer	Northrop Grumman
First flight	17 July 1989
Introduction	April 1997
Status	In service
Primary user	United States Air Force
Produced	1987–2000
Number built	21
Program cost	US\$44.75 billion (through 2004)
Unit cost	\$737 million (1997 approx flyaway cost)

Performance

Maximum speed: Mach 0.95 (550 knots, 630 mph, 1,010 km/h) at 40,000 ft altitude / Mach 0.95 at sea level
 Cruise speed: Mach 0.85[63] (487 knots, 560 mph, 900 km/h) at 40,000 ft altitude
 Range: 6,000 nmi (11,100 km (6,900 mi))
 Service ceiling: 50,000 ft (15,200 m)
 Wing loading: 67.3 lb/ft² (329 kg/m²)
 Thrust/weight: 0.205

Armament

2 internal bays for ordnance and payload with an official limit of 40,000 lb (18,000 kg); maximum estimated limit is 50,000 lb (23,000 kg).
 80× 500 lb class bombs (Mk-82, GBU-38) mounted on Bomb Rack Assembly (BRA)
 36× 750 lb CBU class bombs on BRA
 16× 2,000 lb class bombs (Mk-84, GBU-31) mounted on Rotary Launcher Assembly (RLA)
 16× B61 or B83 nuclear bombs on RLA (strategic mission)
 Standoff weapon: AGM-154 Joint Standoff Weapon (JSOW) and AGM-158 Joint Air-to-Surface Standoff Missile (JASSM)

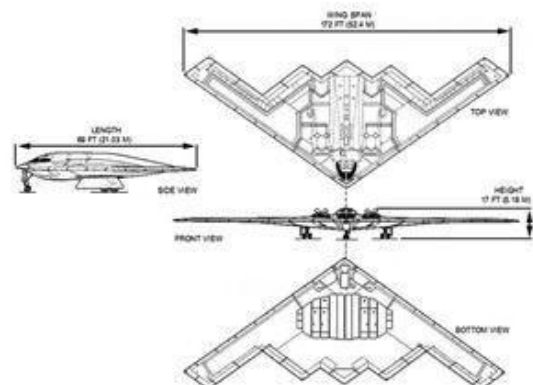

Air Vehicle No	Block No	USAF s/n	Formal name	Time in service, status
AV-1	Test/30	82-1066	Spirit of America	14 July 2000 – Active
AV-2	Test/30	82-1067	Spirit of Arizona	4 December 1997 – Active
AV-3	Test/30	82-1068	Spirit of New York	10 October 1997 – Active
AV-4	Test/30	82-1069	Spirit of Indiana	22 May 1999 – Active
AV-5	Test/20	82-1070	Spirit of Ohio	18 July 1997 – Active
AV-6	Test/30	82-1071	Spirit of Mississippi	23 May 1997 – Active
AV-7	10	88-0328	Spirit of Texas	21 August 1994 – Active
AV-8	10	88-0329	Spirit of Missouri	31 March 1994 – Active
AV-9	10	88-0330	Spirit of California	17 August 1994 – Active
AV-10	10	88-0331	Spirit of South Carolina	30 December 1994 – Active
AV-11	10	88-0332	Spirit of Washington	29 October 1994 – Severely damaged by fire in February 2010, repaired.
AV-12	10	89-0127	Spirit of Kansas	17 February 1995 – 23 February 2008, crashed
AV-13	10	89-0128	Spirit of Nebraska	28 June 1995 – Active
AV-14	10	89-0128	Spirit of Georgia	14 November 1995 – Active
AV-15	10	90-0040	Spirit of Alaska	24 January 1996 – Active
AV-16	10	90-0041	Spirit of Hawaii	10 January 1996 – Active
AV-17	20	92-0700	Spirit of Florida	3 July 1996 – Active
AV-18	20	93-1085	Spirit of Oklahoma	15 May 1996 – Active, Flight Test
AV-19	20	93-1086	Spirit of Kitty Hawk	30 August 1996 – Active
AV-20	30	93-1087	Spirit of Pennsylvania	5 August 1997 – Active
AV-21	30	93-1088	Spirit of Louisiana	10 November 1997 – Active
AV-22 through AV-165				Cancelled

B-2“幽灵”(英语: Spirit)是目前世界上唯一的隐身战略轰炸机,于1981年10月20日打败洛克希德/洛克威尔,由诺斯洛普/波音团队赢得先进技术轰炸机计划(The Advanced Technology Bomber, ATB),在麻省理工学院科学家协助之下为美国空军研制生产。1997年,首批六架B-2轰炸机正式服役,而至今一共只生产21架。在F-117A夜鹰攻击机退役, F-35闪电II式战斗机尚未服役之时, B-2与F-22猛禽式战斗机为目前世界上仅有可以进行地对地攻击任务的隐身型机种。每架B-2造价为24亿美元,若以重量计, B-2的重量单位价格比黄金还要贵两至三倍(最初装备时)。

目前B-2有三个型号, 1993年12月交付的Block10型, 1995年交付的Block20和1997年的Block30。美军在大幅度改善B-2的常规高精度打击能力,并逐步解决隐身设计所带来的维护问题。1999年,在北约对塞尔维亚的军事行动中,美军多架B-2轰炸机由美国本土直飞塞国,期间共投下600多枚联合直接攻击弹药(JDAM),是空战中隐身性与准确性的一大革命。在2003年的演习中,一架B-2轰炸机一次投下80枚重达500磅(230公斤)的JDAM,显示出先进的精确饱和攻击能力。

●READ BEFORE ASSEMBLY

1. When you use glue or paint, do not near flame, and use in a well-ventilated room.
2. Take extra care in handling photo etch parts in order to avoid injury
3. When you take parts off the runner frame, use modeling scissors and trim excess plastic with a cutter or a file.
4. Glue and paint are not included.
5. This product is only suitable for experienced more than 14 years old.

●装配之前仔细阅读:

1. 勿於近火处使用胶水或油漆,并打开窗户保持空气流通。
2. 取蚀刻片时应特别注意安全,防止利边划伤手指。
3. 从胶架中取出部件时,应用模型专用剪,并用界刀或小锥除去多余的胶料。
4. 请使用塑料胶水和油漆,模型内不含。
5. 本产品不适合14岁以下没有经验的模型爱好者。

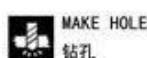

DECAL APPLICATION

1. Cut off decal from sheet.
2. Dip the decal in tepid water 40° C for about 10 sec. and place on a clean cloth.
3. Hold the backing sheet edge and slide decal onto the model.
4. Move decal into position by wetting decal with finger.
5. Press decal gently down with a soft cloth until excess water and air bubbles are gone.

水贴纸的使用:

1. 从水贴纸上剪下印花。
2. 将印花放入温水中浸10秒,然后放在干净布上。
3. 拿着印花纸板将印花移到模型上。
4. 手指蘸水将印花移到适当的位置。
5. 用软布轻压印花直至不干,汽泡消失。

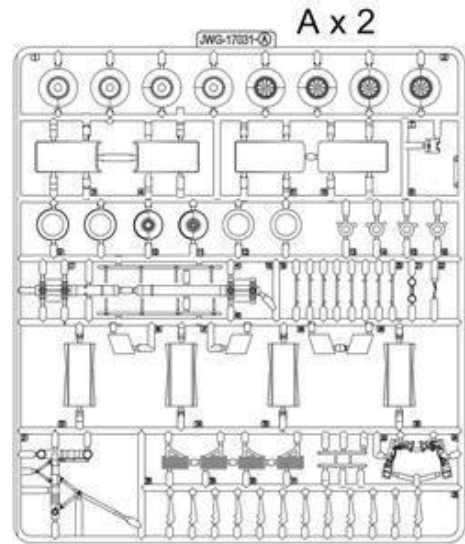
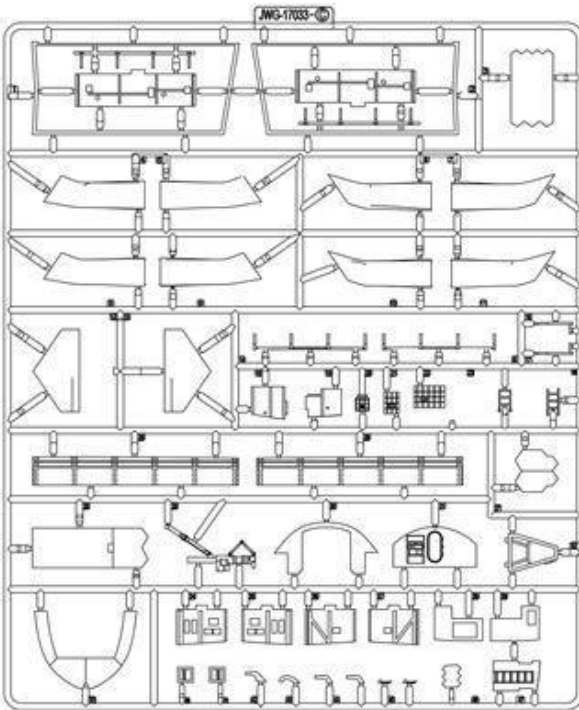
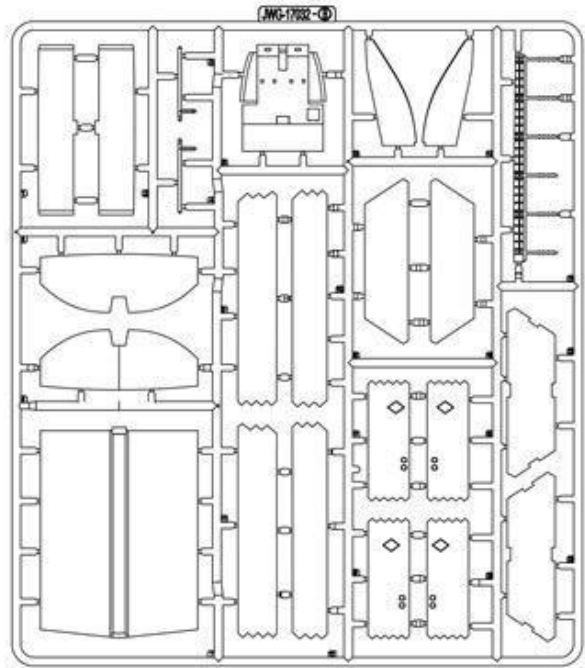
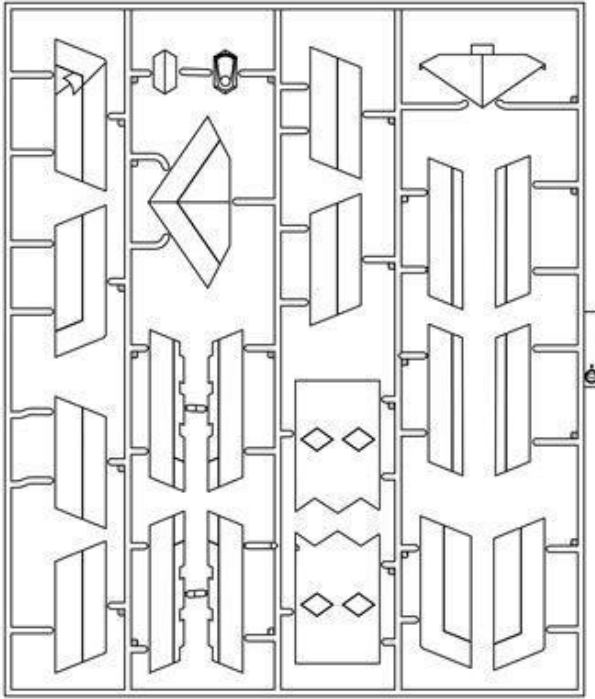

A x 2

F x 2

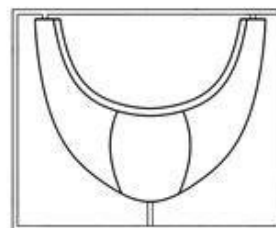
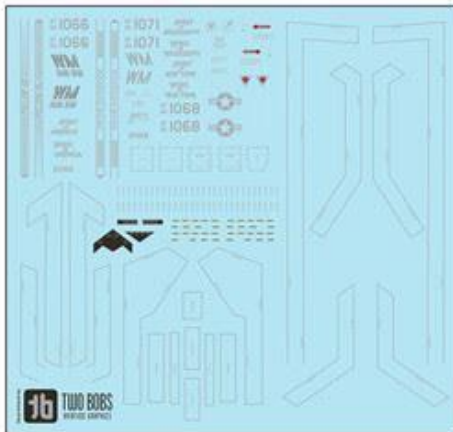
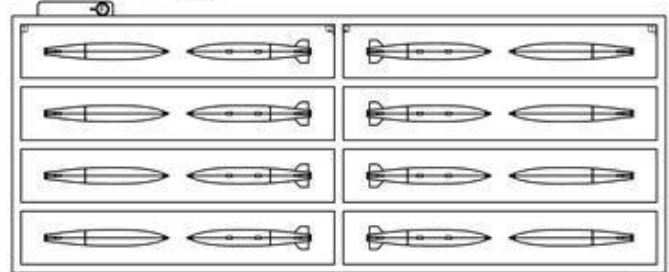

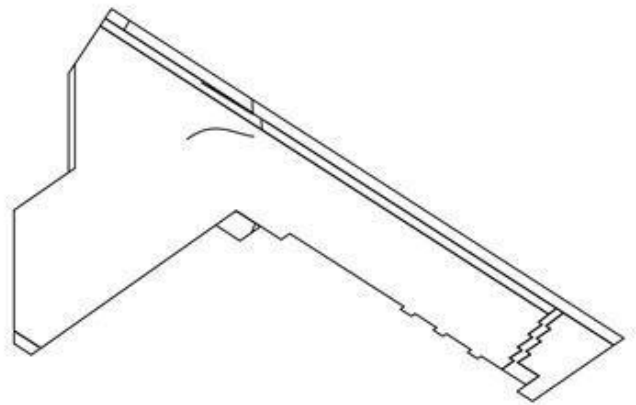
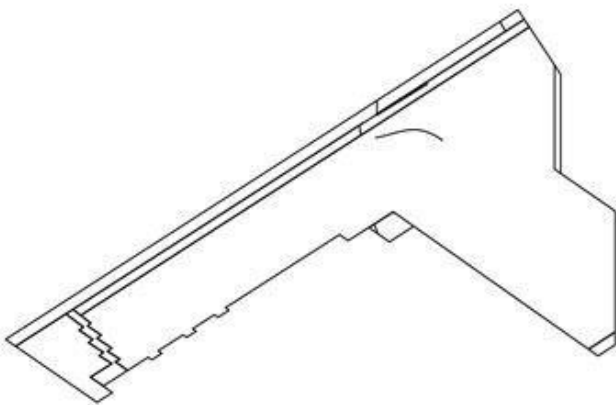
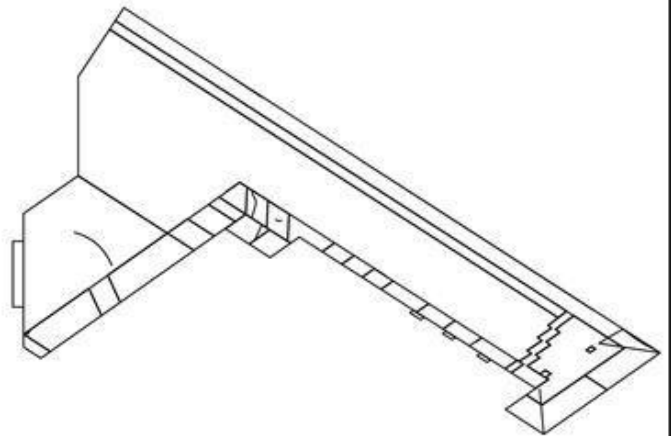
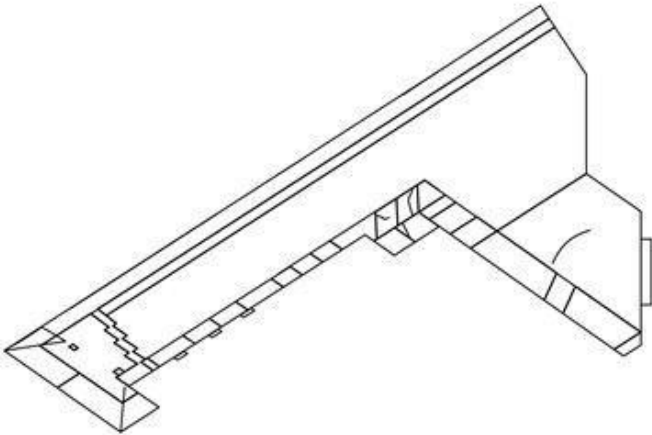
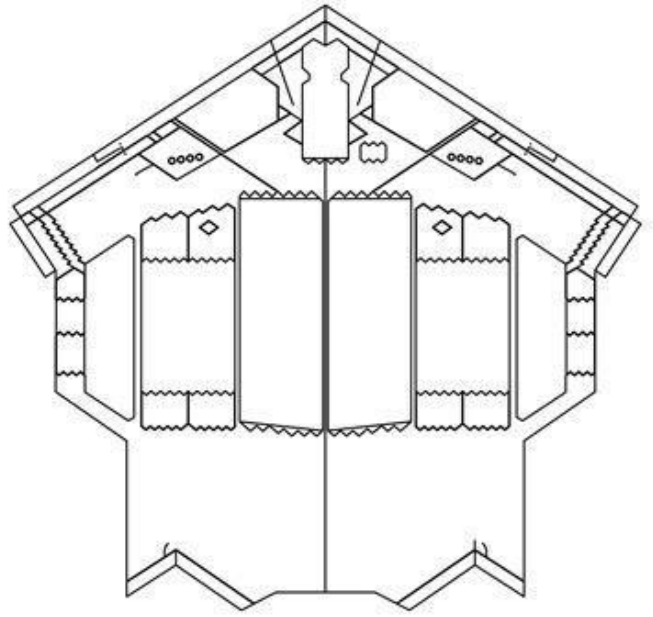
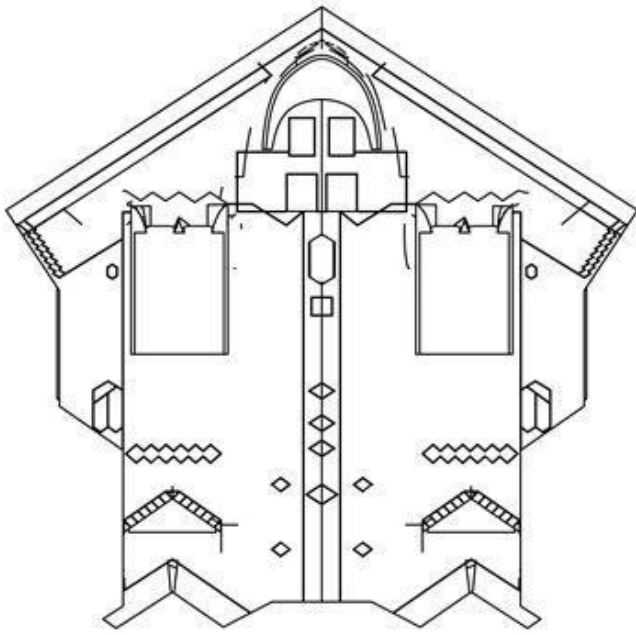

1

組合駕駛室
組合駕駛室 1
Attaching cockpit

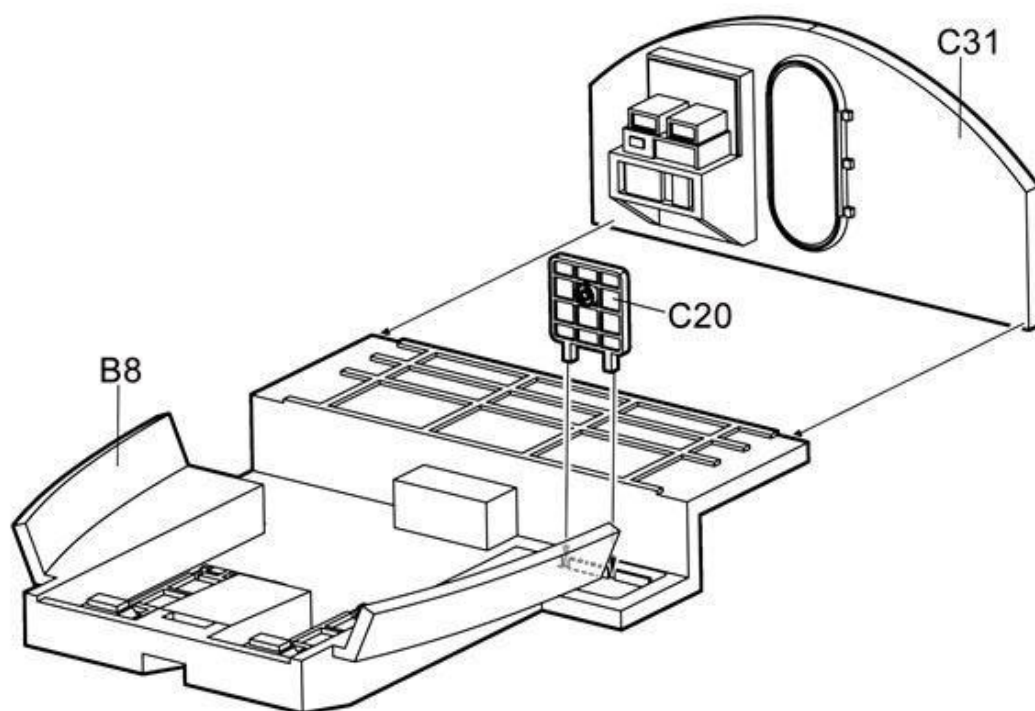

2

組合駕駛室 2
組合駕駛室 2
Attaching cockpit

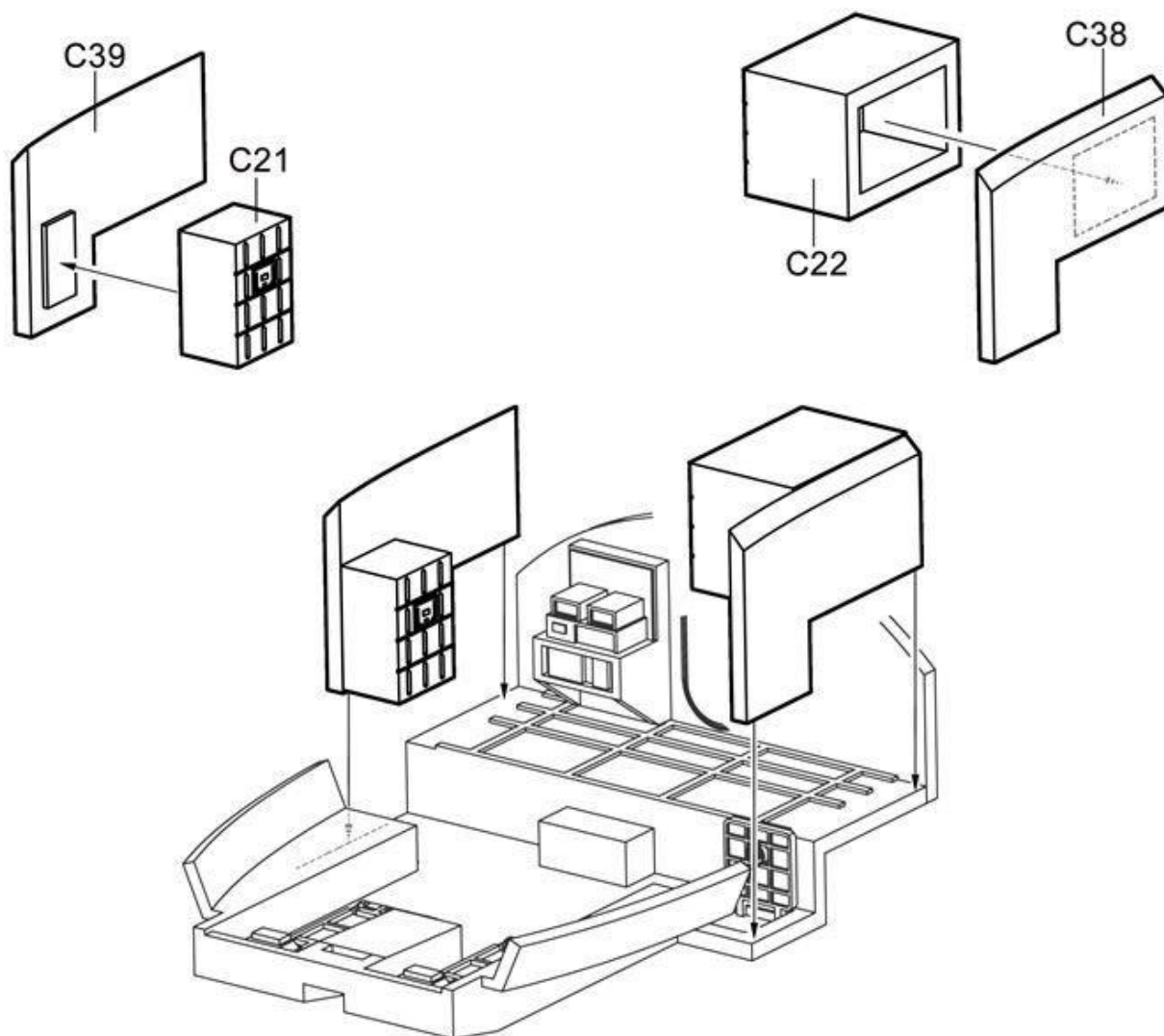

3
組合階段 3
Attaching cockpit

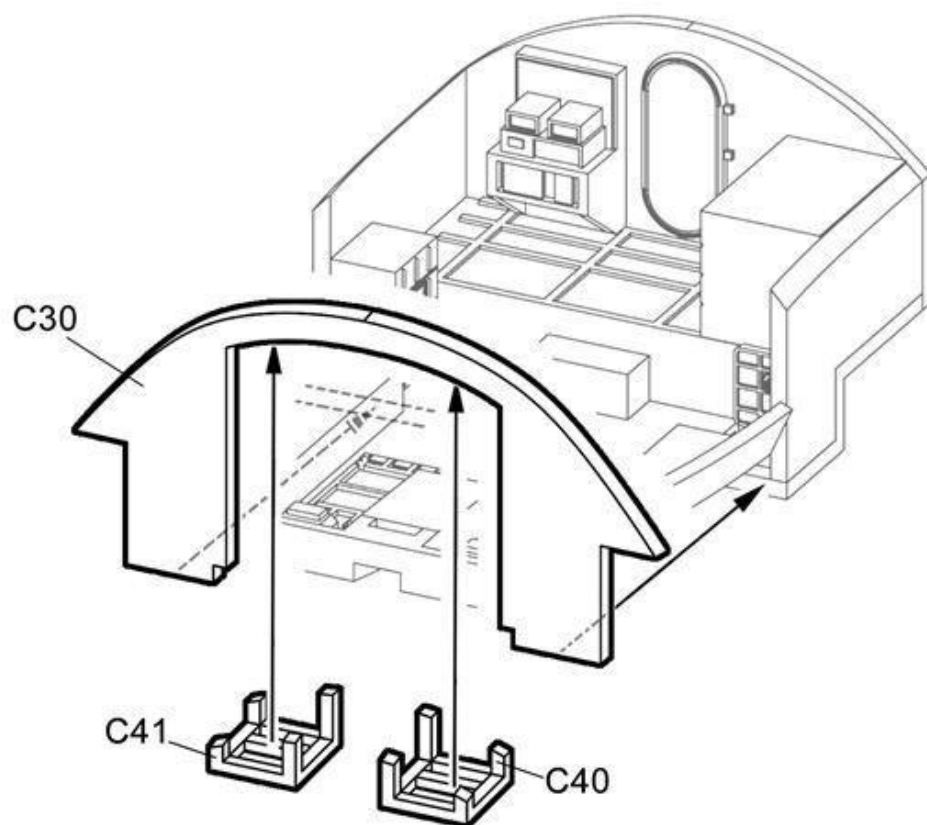

4
組合階段 4
Attaching cockpit

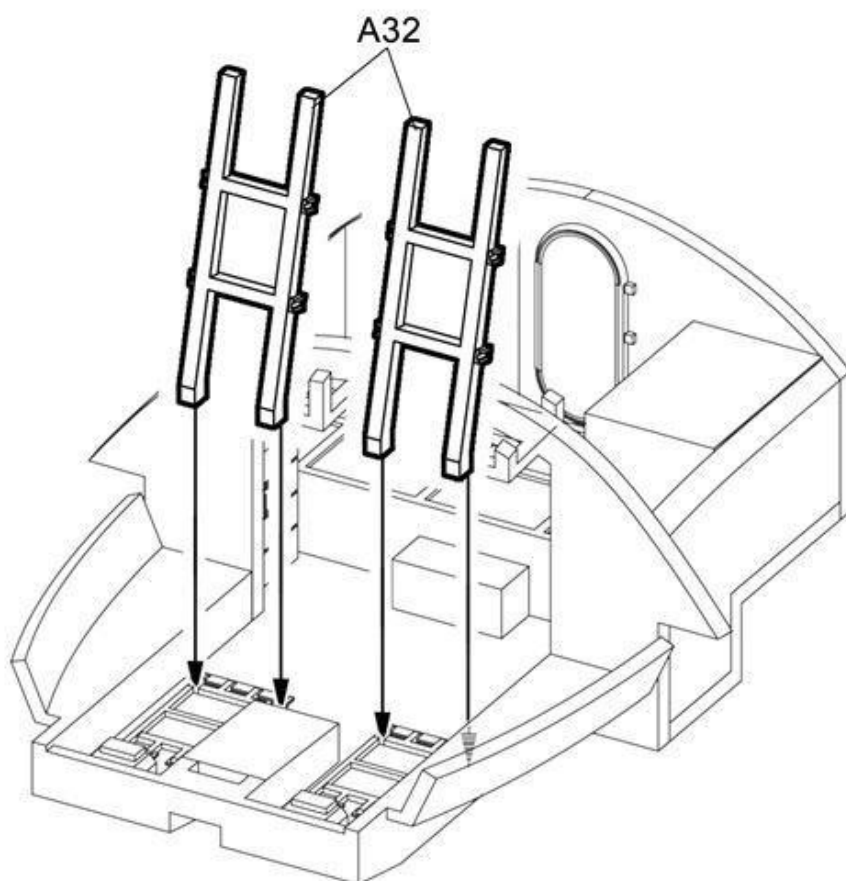

5

組合駕駛室 5
組合駕駛室 5
Attaching cockpit

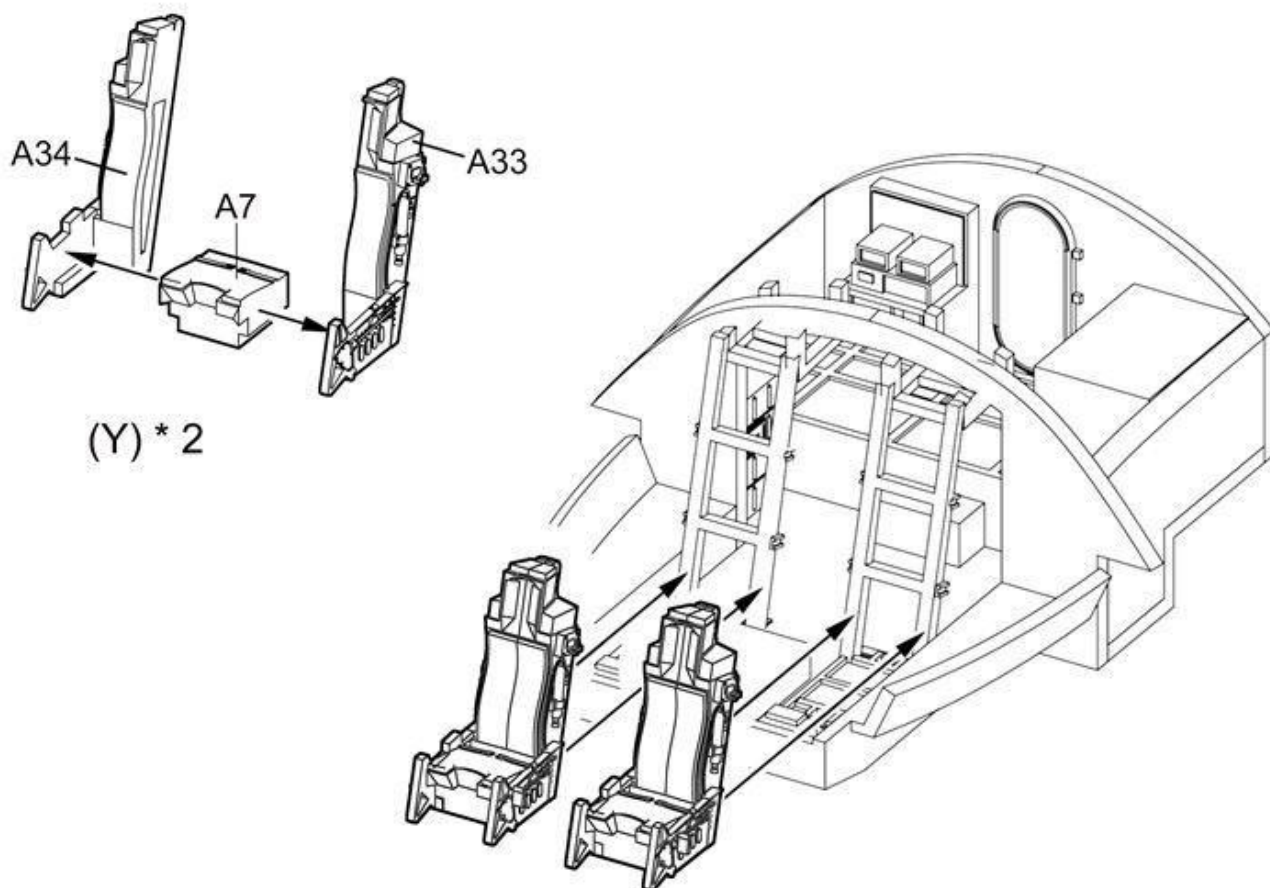

6

組合駕駛儀表盤PE 1
組合駕駛儀表盤PE 1
Attaching driving instrument panel part in cockpit

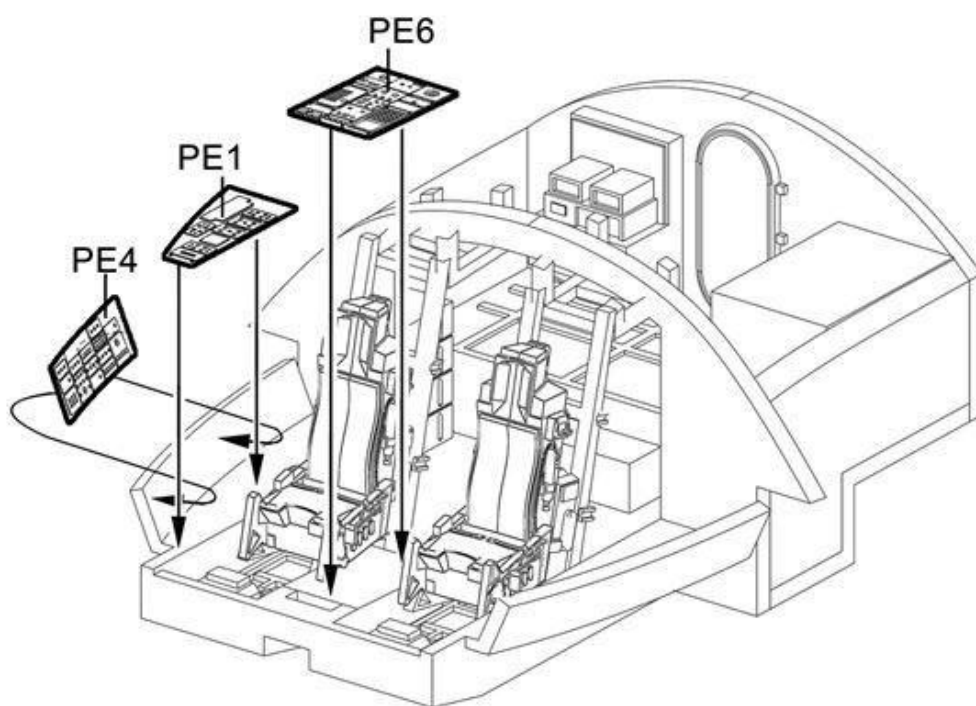

7

組合駕駛儀表面PE 2
組合駕駛儀表面PE 2
Attaching driving instrument panel part in cockpit

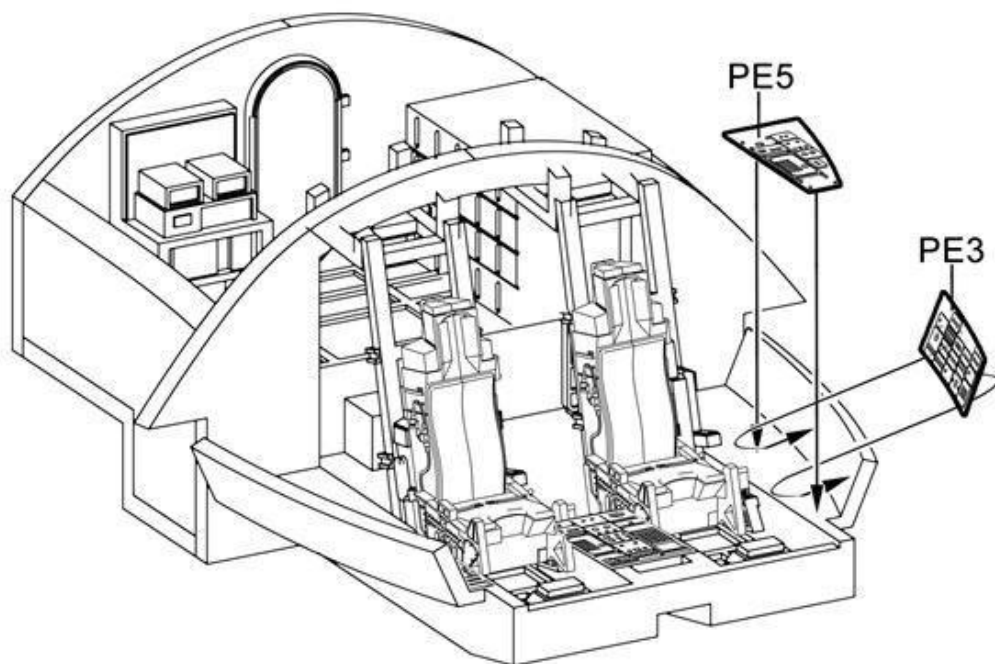

8

組合駕駛空操作杆
組合駕駛空操作杆
Attaching cockpit operating lever

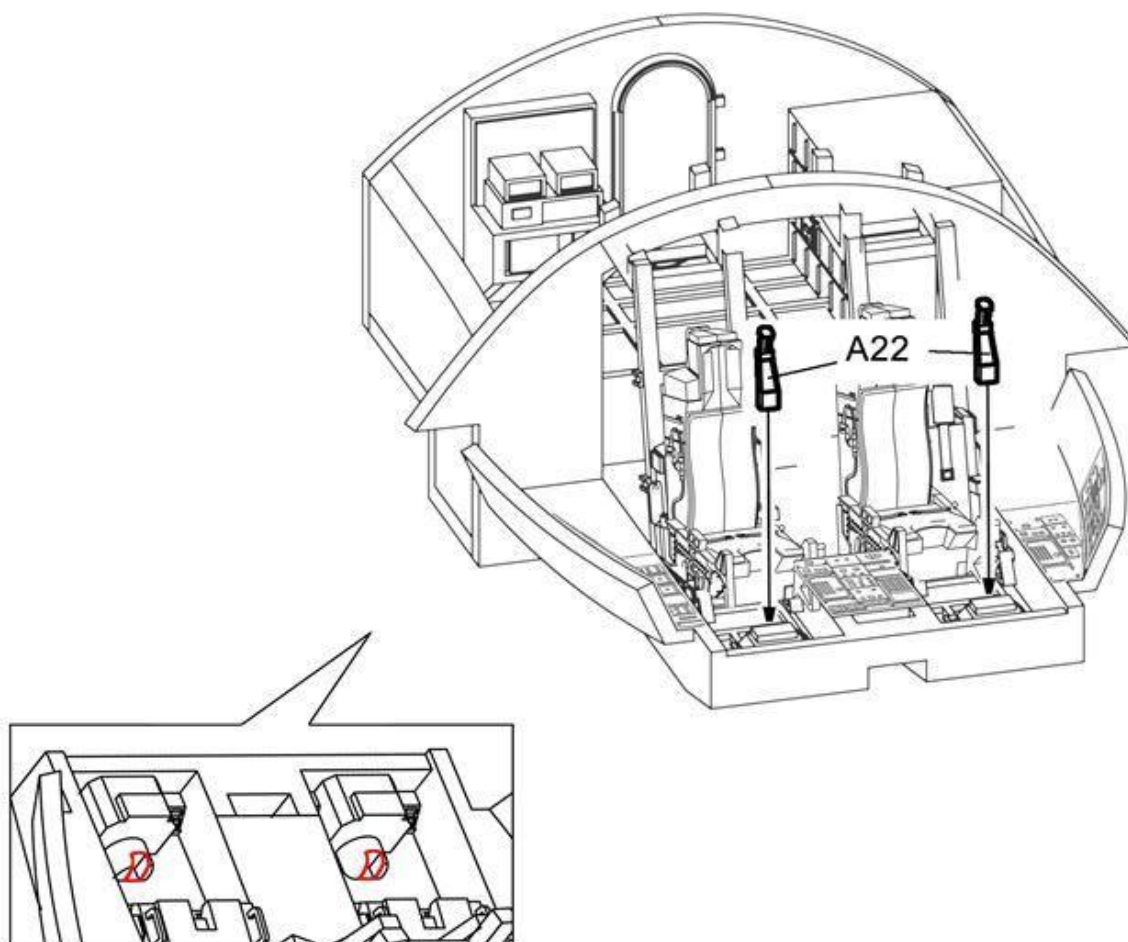

9

組合駕駛儀表面盤
組合駕駛儀表面盤
Attaching driving instrument panel part in cockpit.

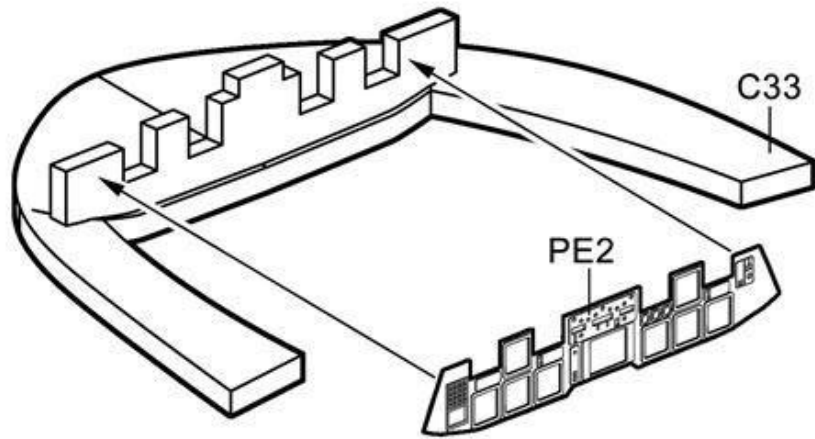

10

組合駕駛室
組合駕駛室
Attaching cockpit

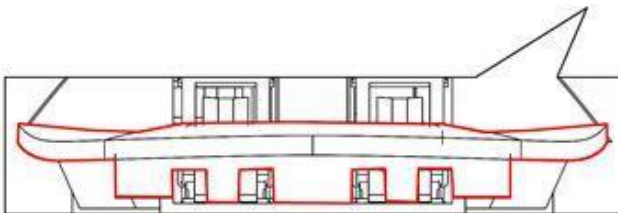
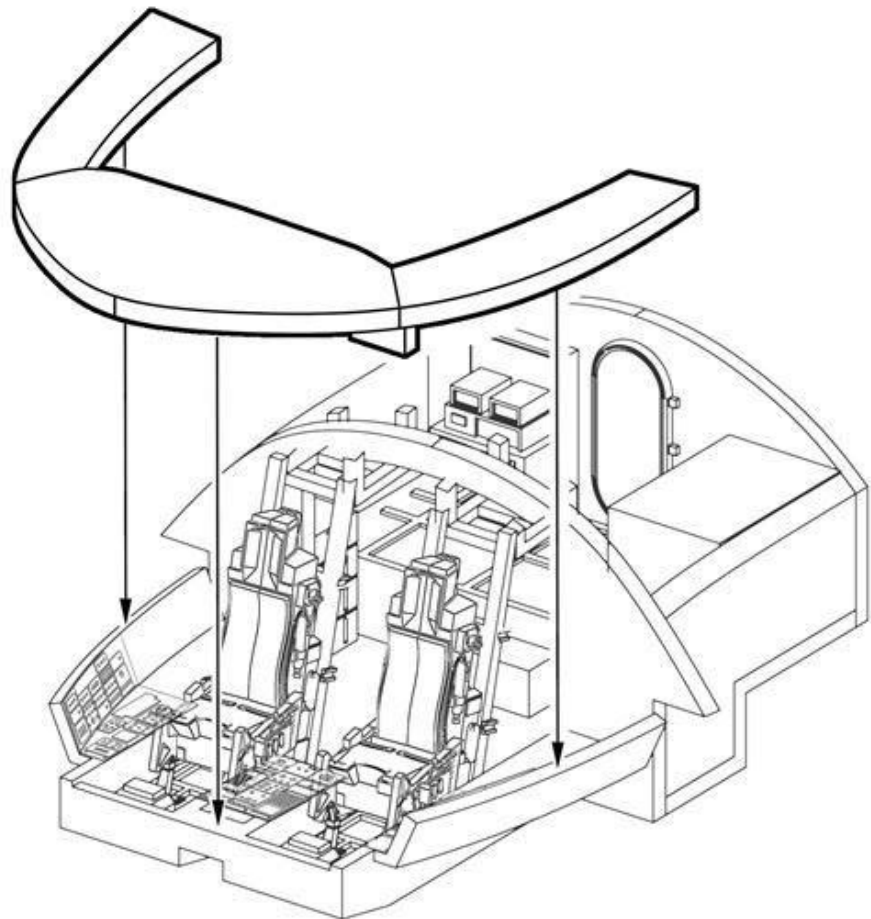

11 組合起落架 1
組合起落架 1
Attaching landing gear

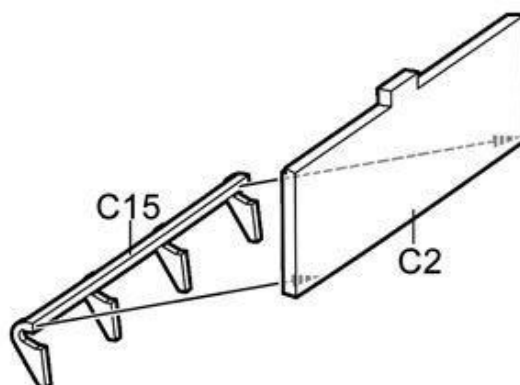
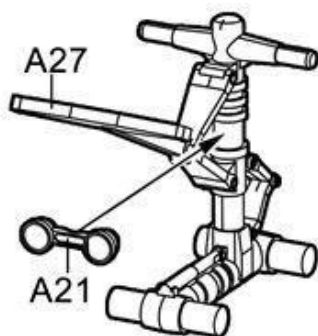
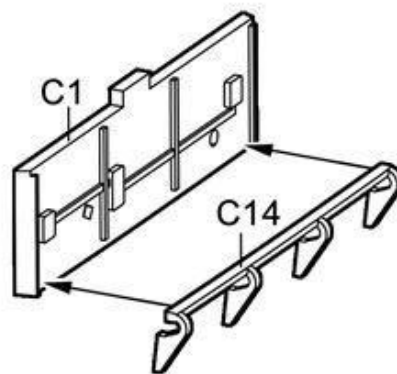
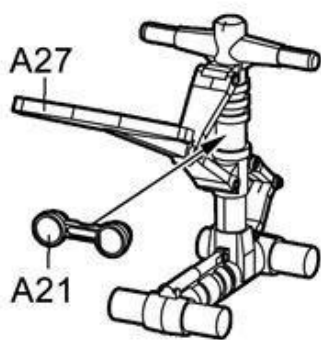

12 組合起落架 2
組合起落架 2
Attaching landing gear

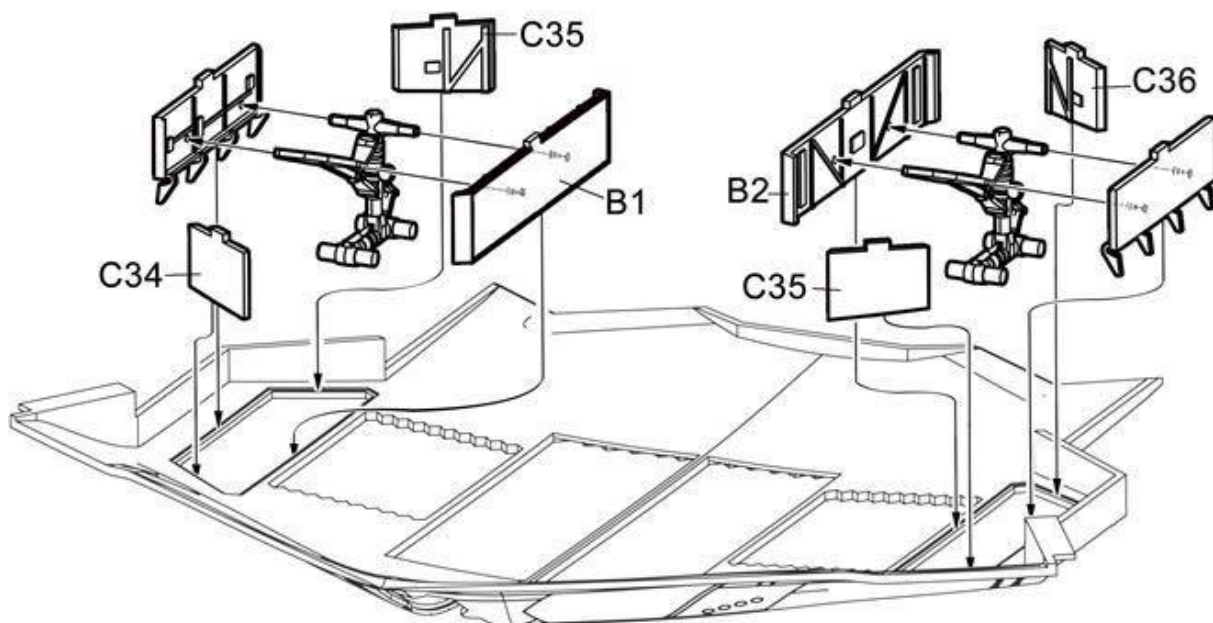

13 組合炸彈掛架
 組合炸彈掛架
 Attaching bomb bay

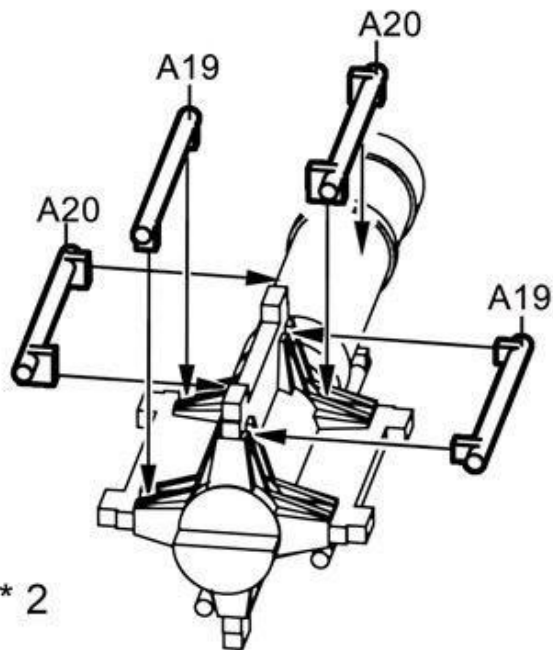
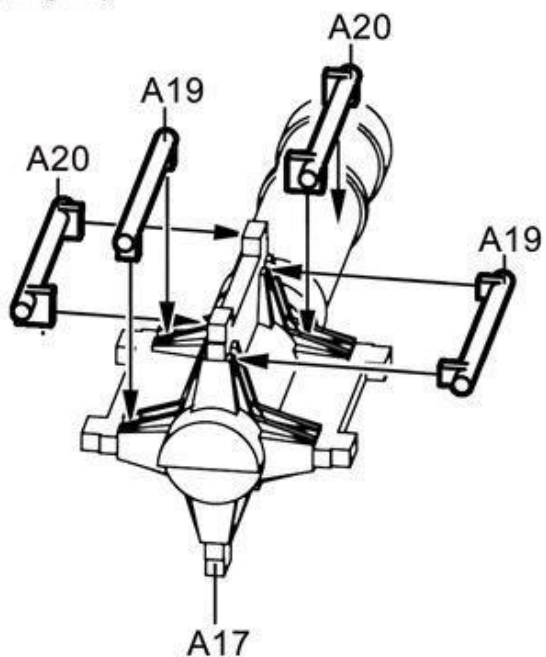

(D) * 2

14 組合炸彈掛架 I
 組合炸彈掛架 I
 Attaching bomb bay

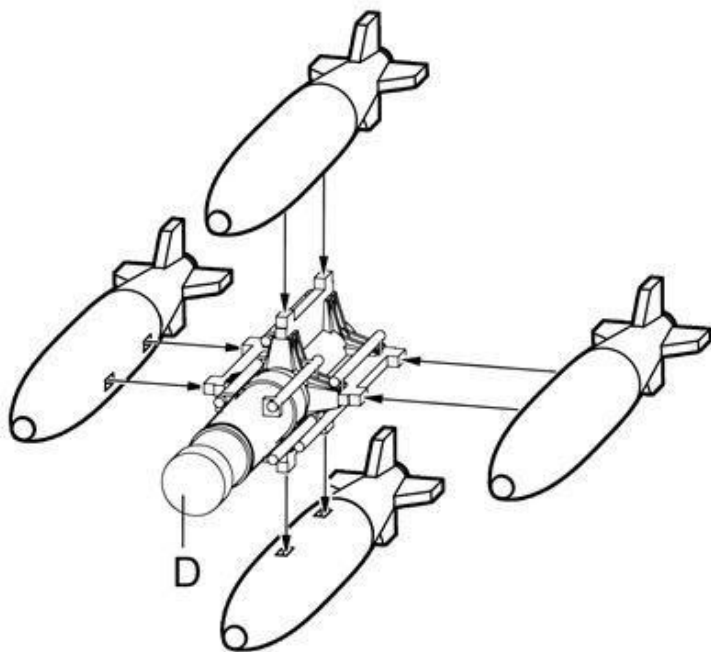

(Q) * 2

(D) * 16

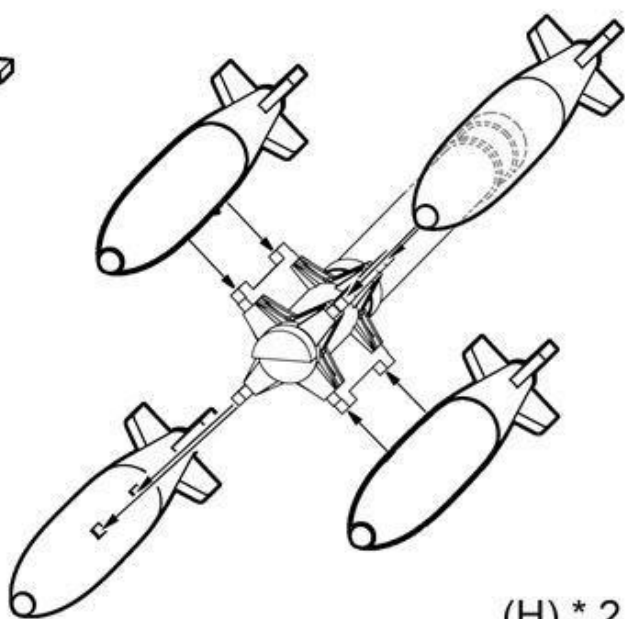
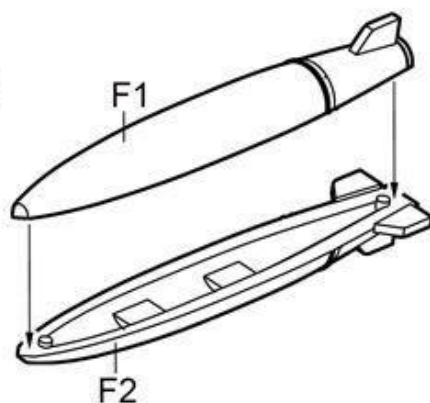

(H) * 2

15 組合機件 2
組合機件 2
Attaching bomb bay

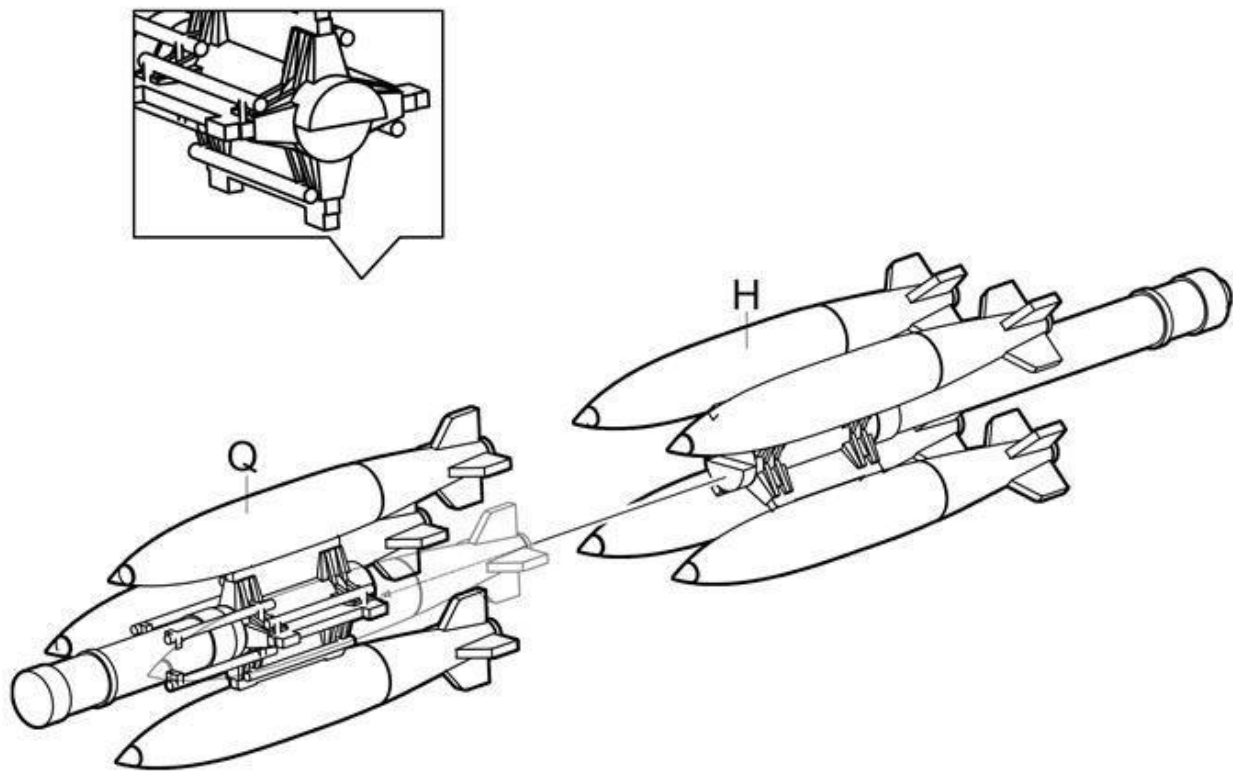

16 組合機件 1
組合機件 1
Attaching bomb bay

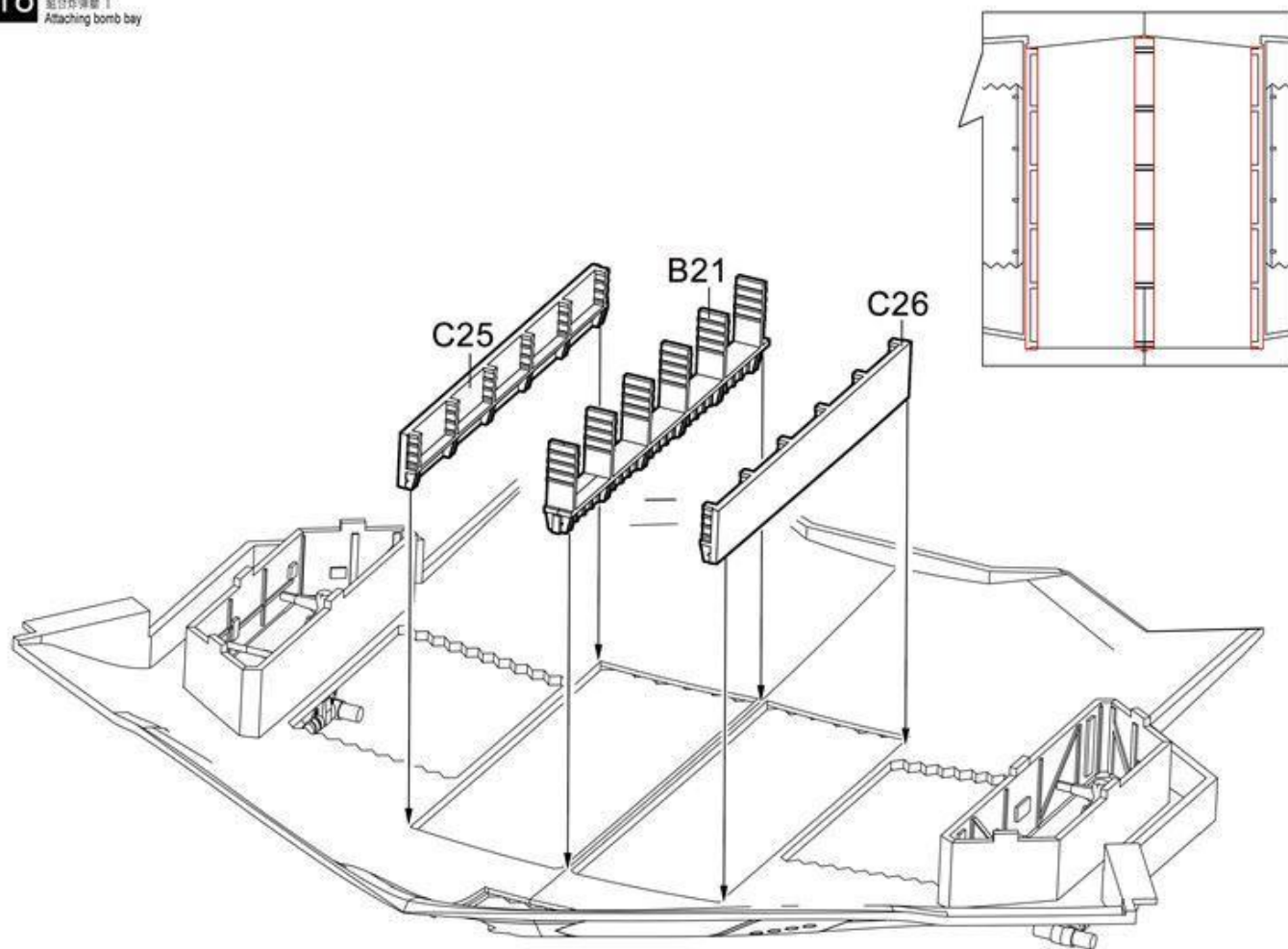

17 组合炸弹舱
 组合炸弹舱
 Attaching bomb bay

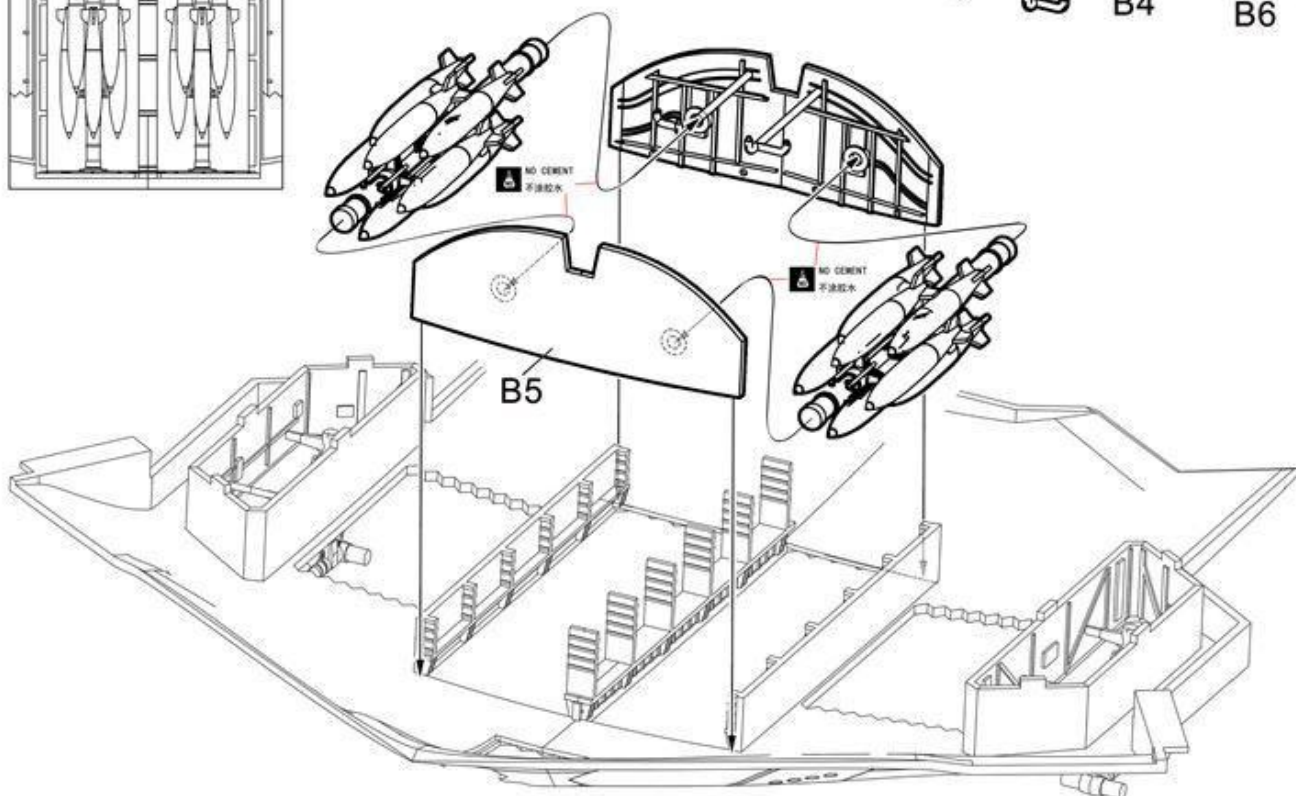
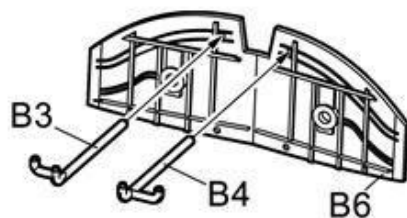
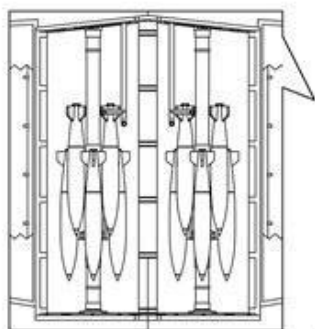

18 组合发动机舱
 组合发动机舱
 Attaching engine compartment

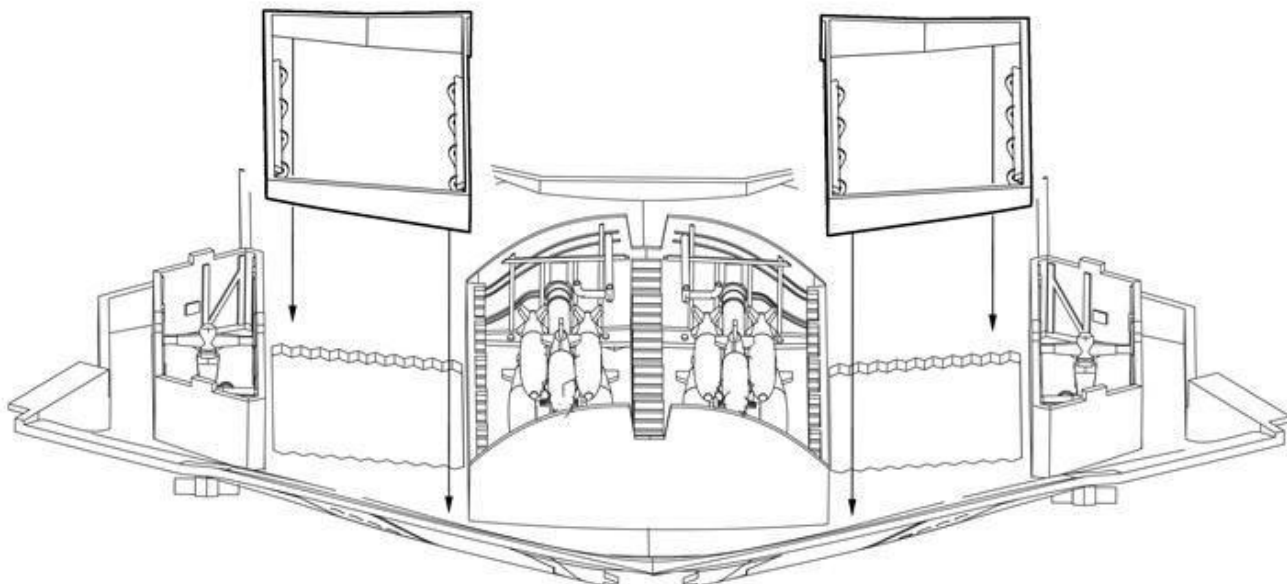
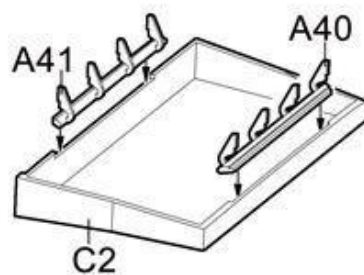
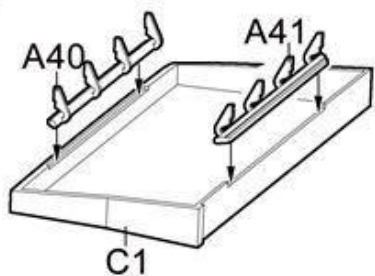

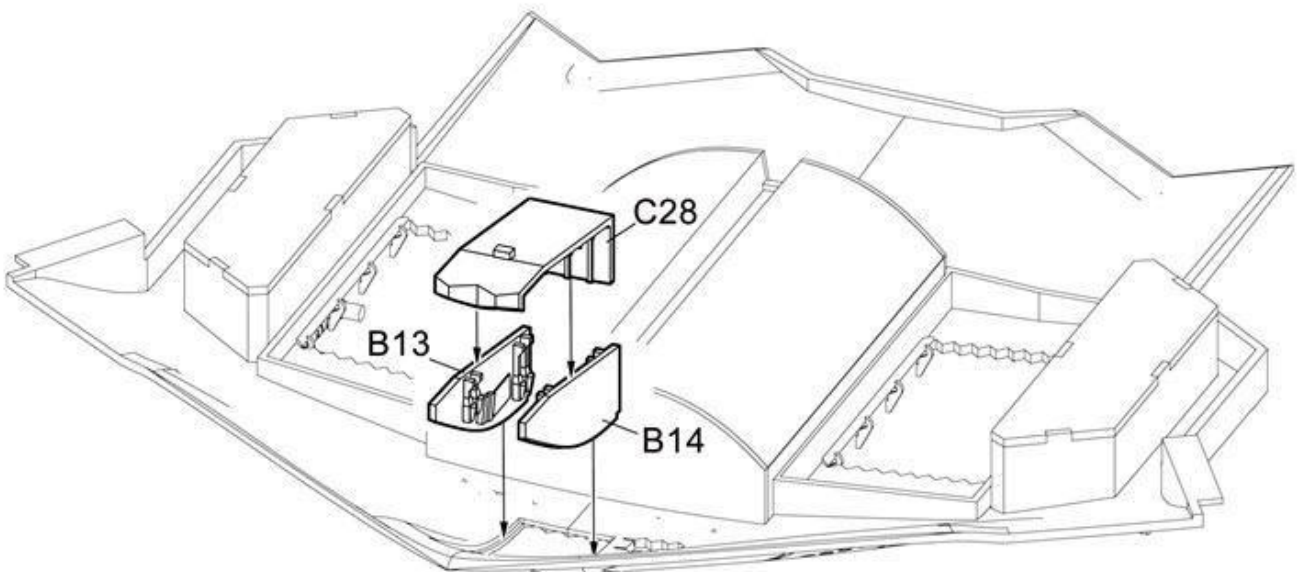
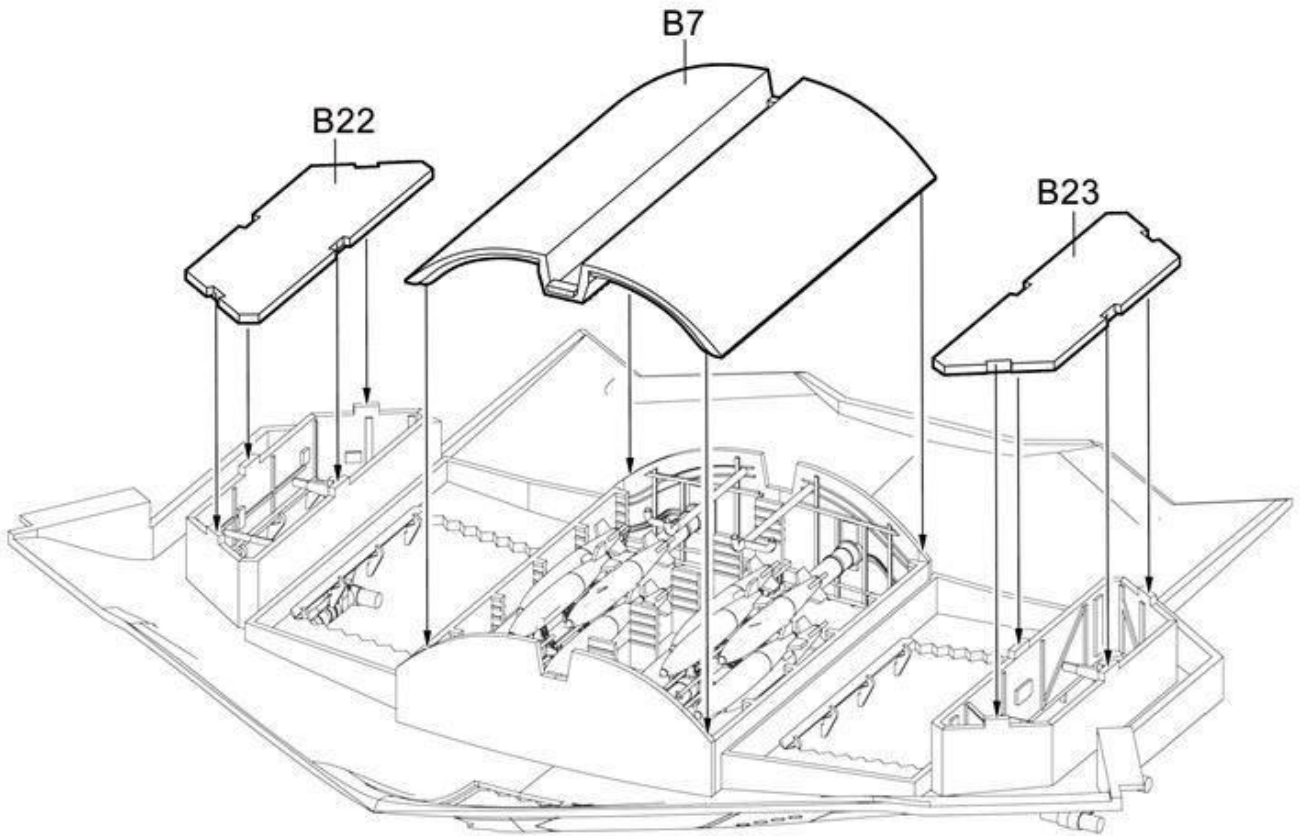

21 組合登機口 1
組合登機口 1
Attaching Boarding port

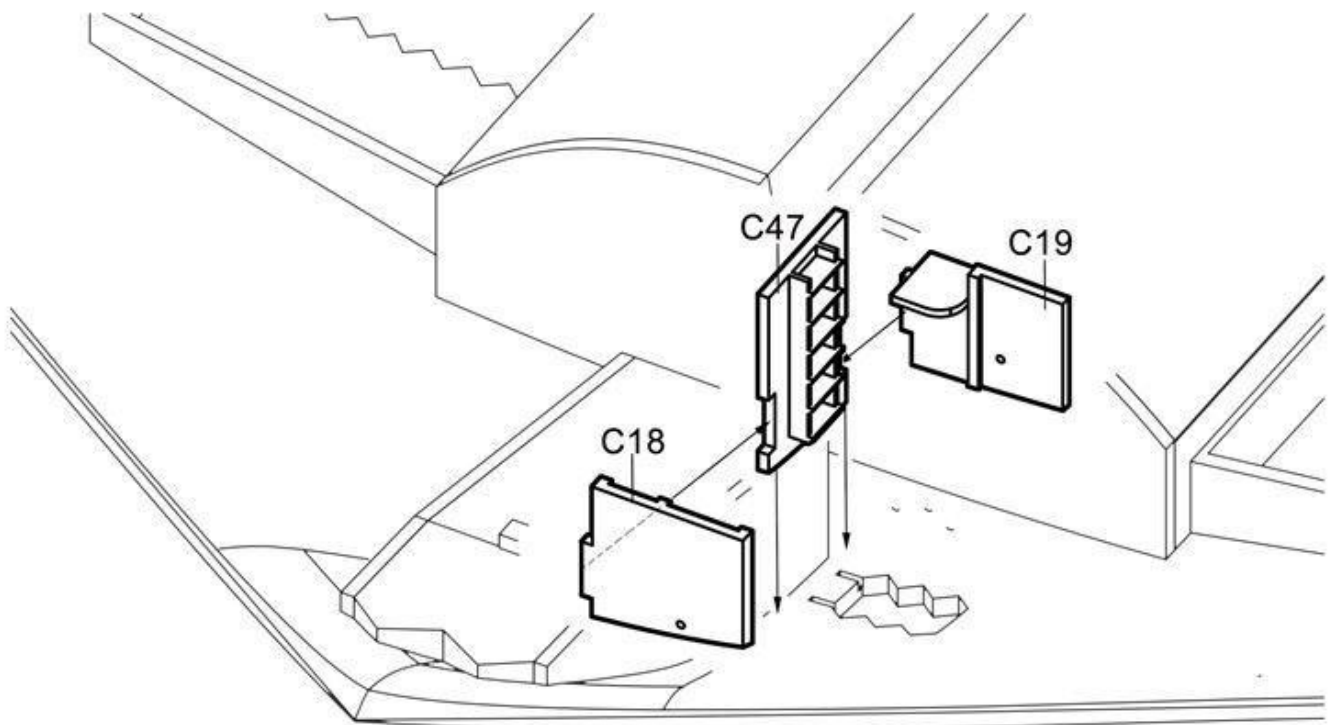

22 組合登機口 2
組合登機口 2
Attaching Boarding port

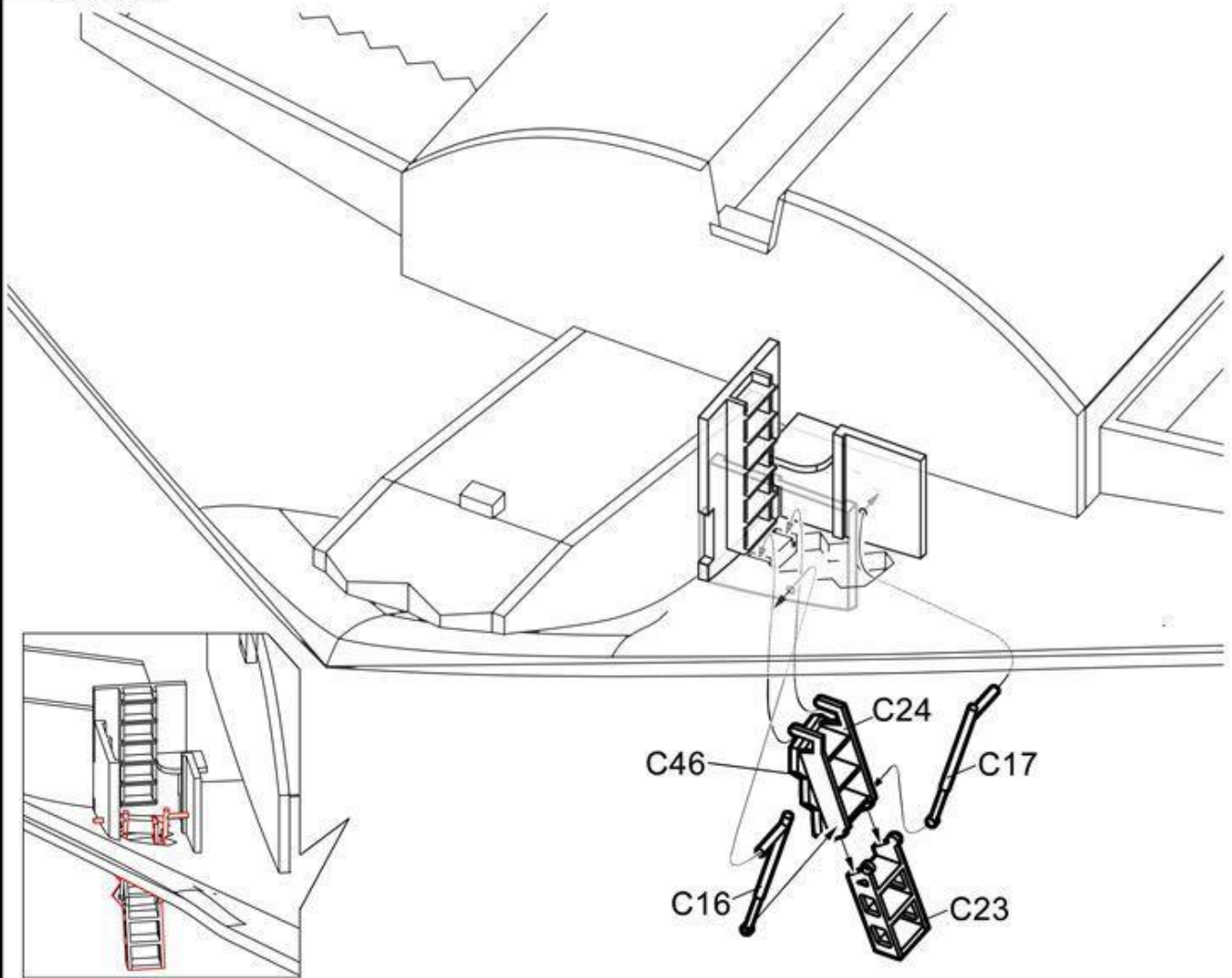

23 组合驾驶室
组合驾驶舱
Attaching cockpit

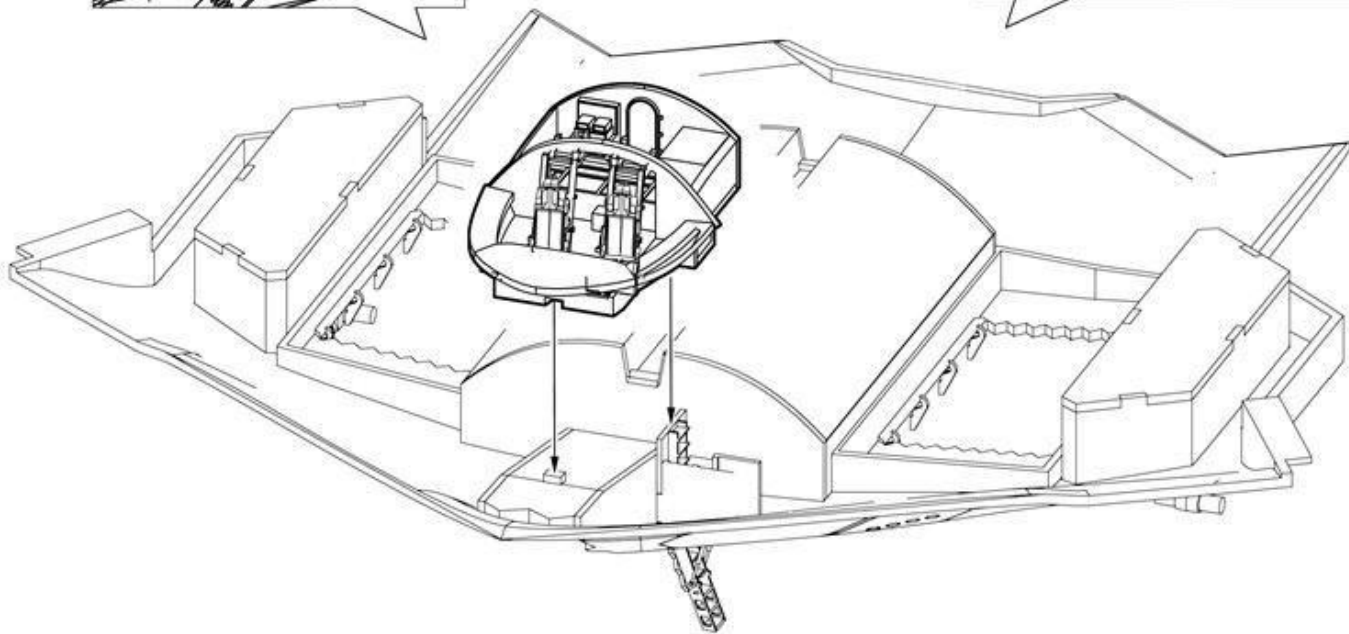
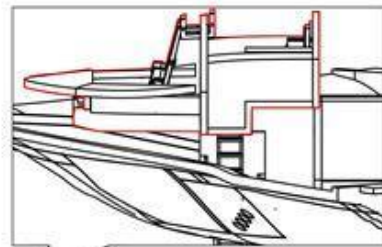
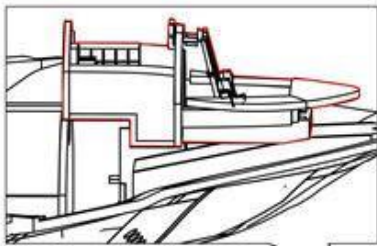

24 组合发动机舱外壳
组合发动机舱外壳
Attaching engine compartment part

Or open status

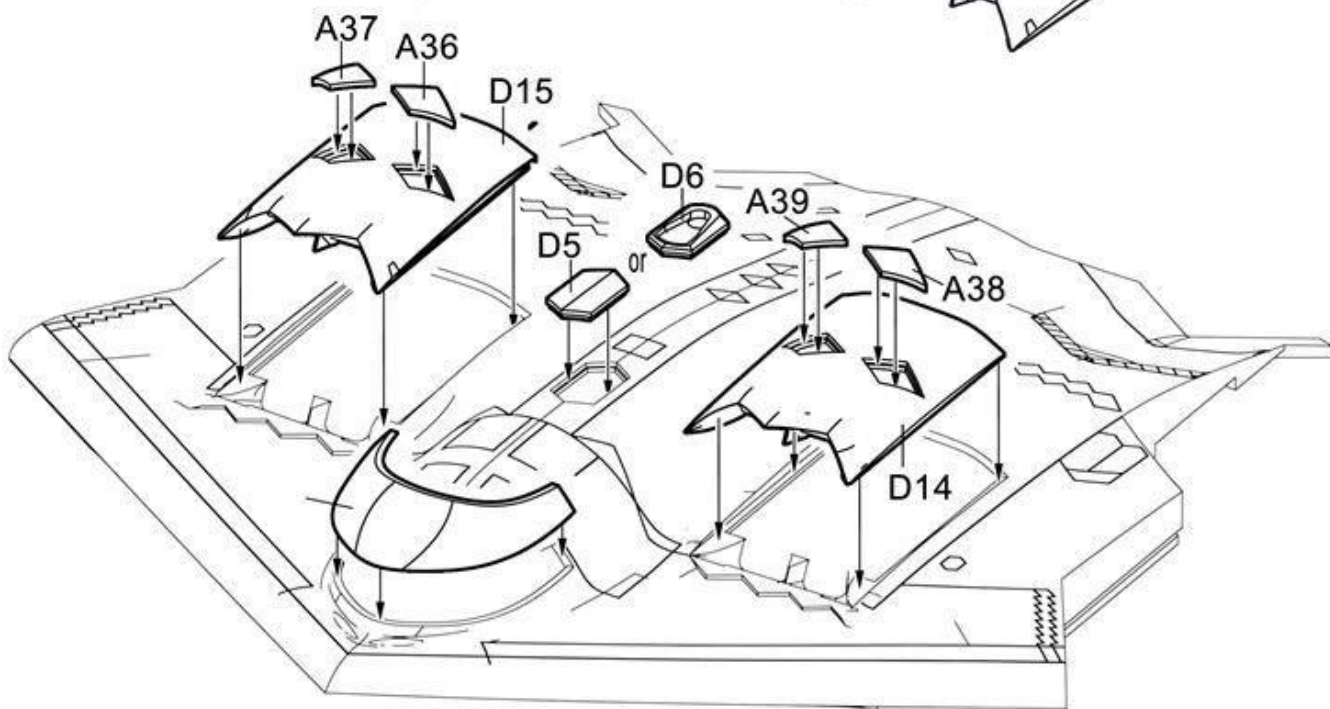

(P)*4

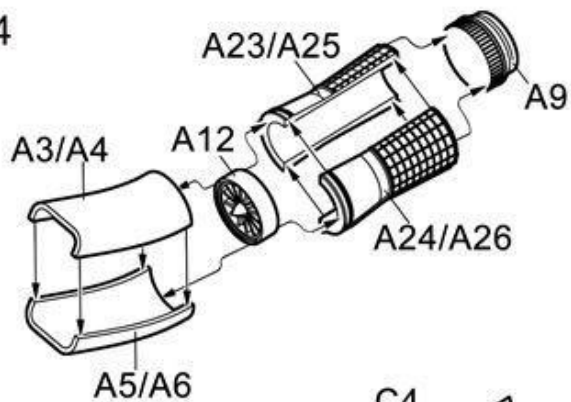

(G3)

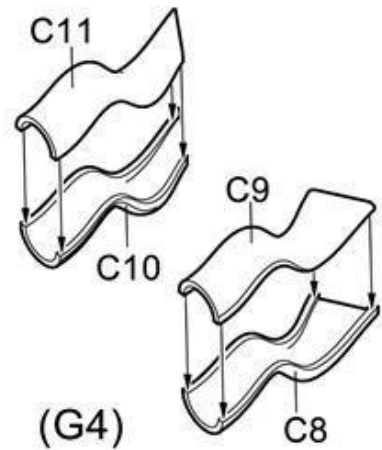

(G1)

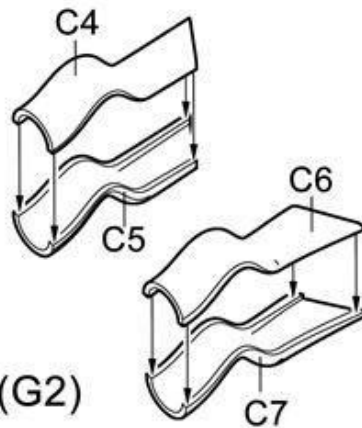

(G4)

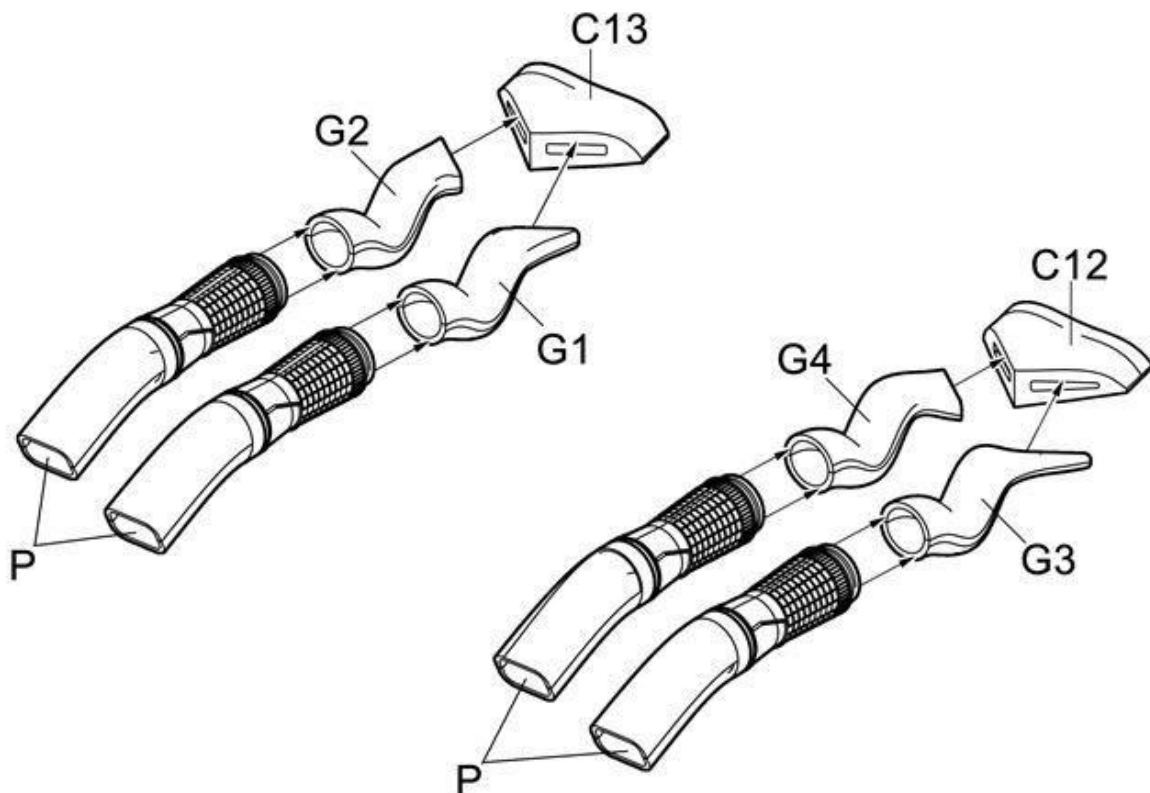

27

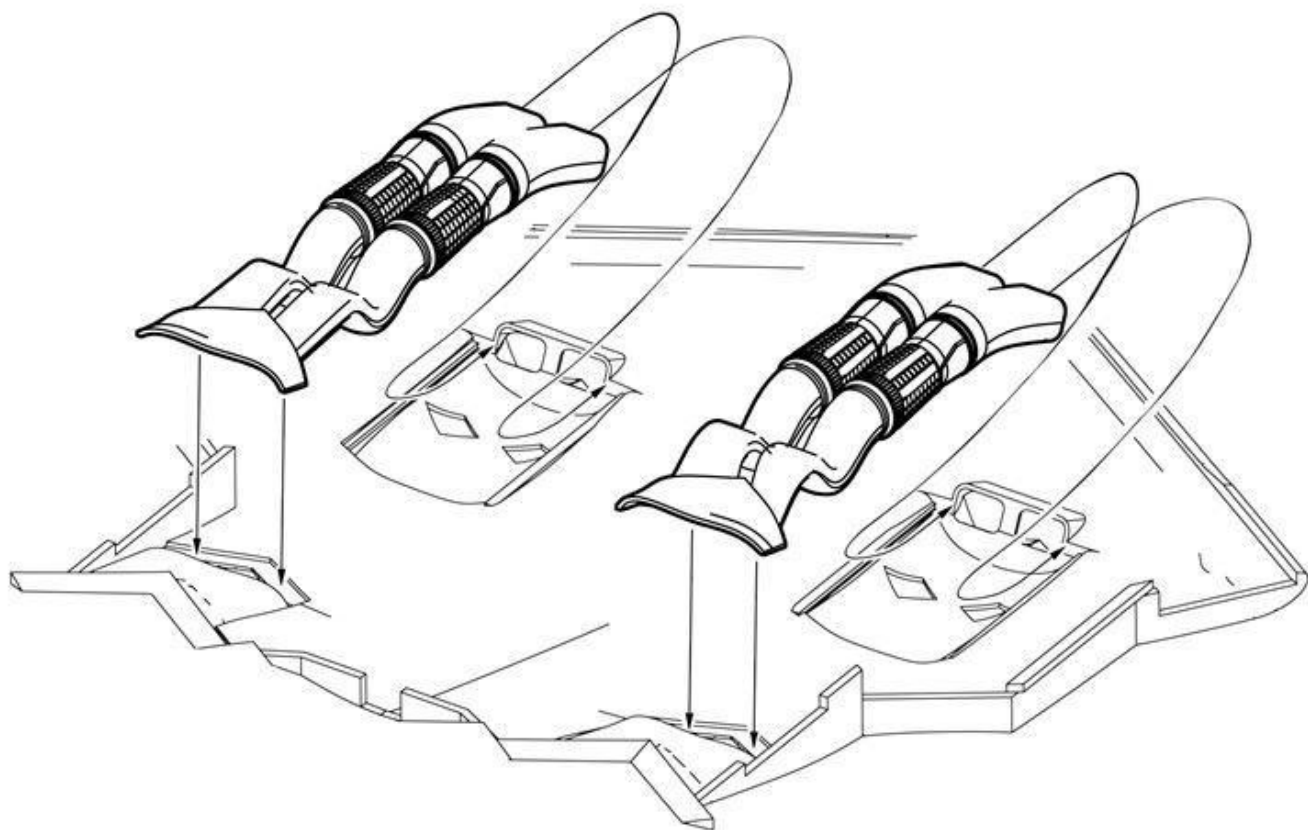
組合发动机 3
組合發動機 3
Attaching engine

28

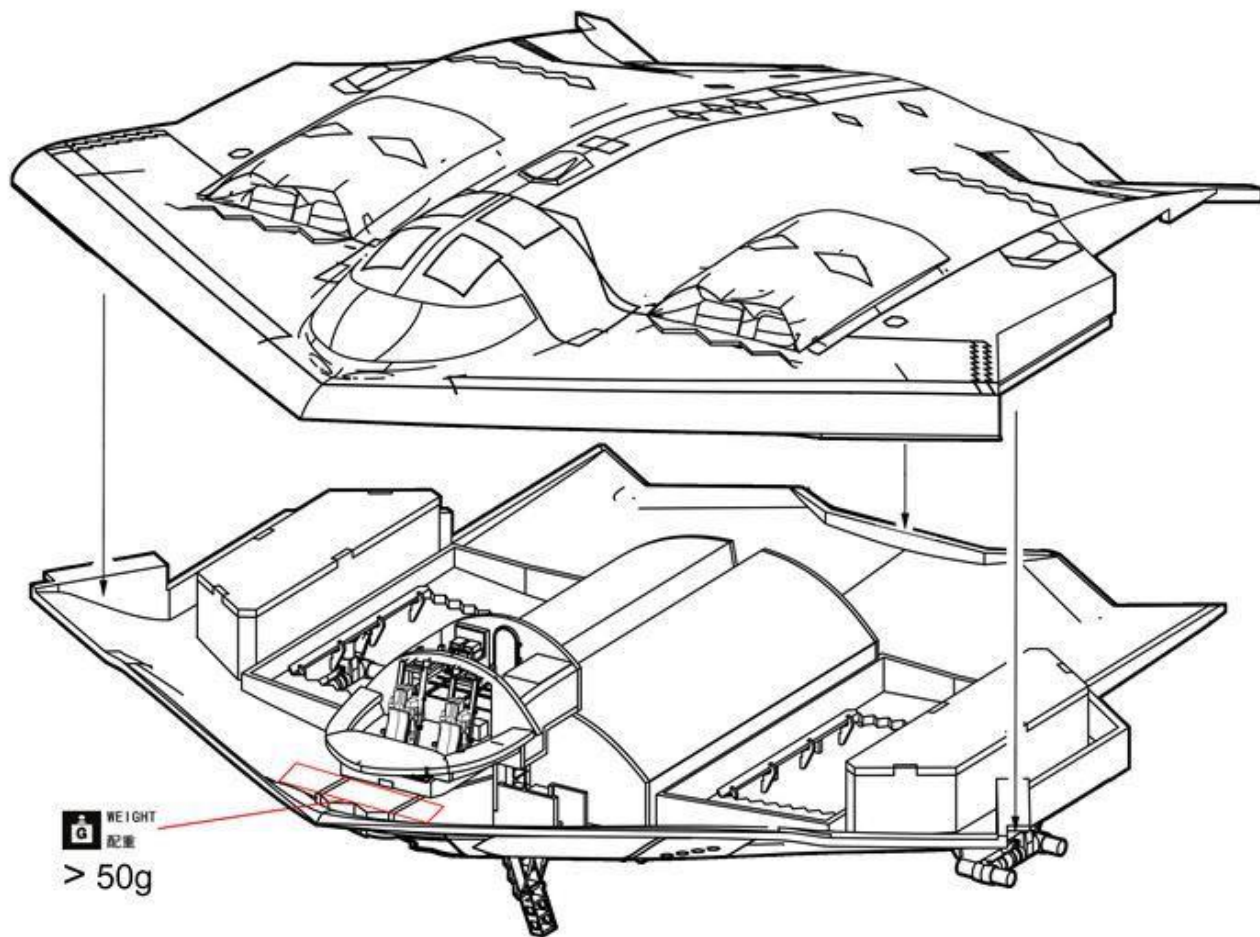
組合机体
組合機體
Attaching aircraft body

(L) * 8

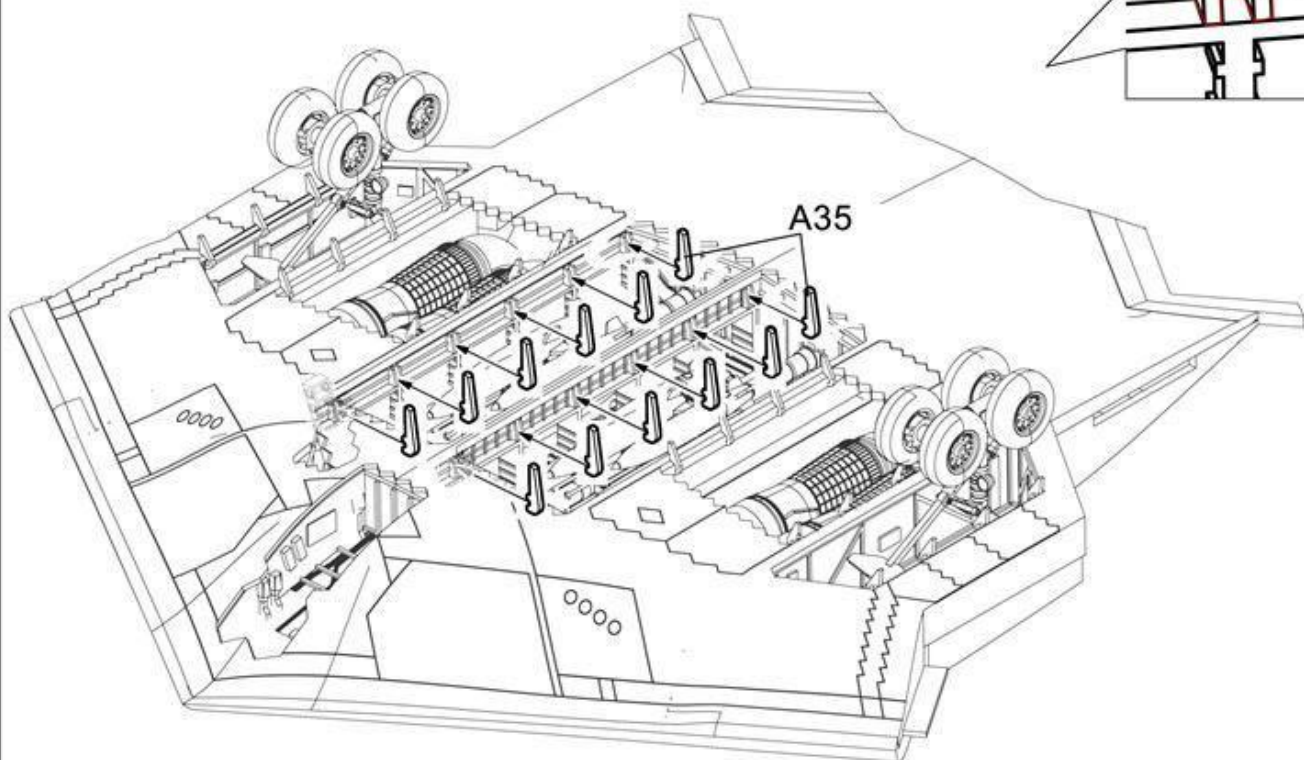
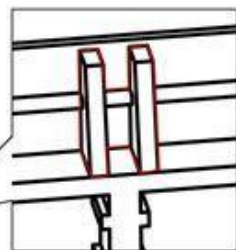
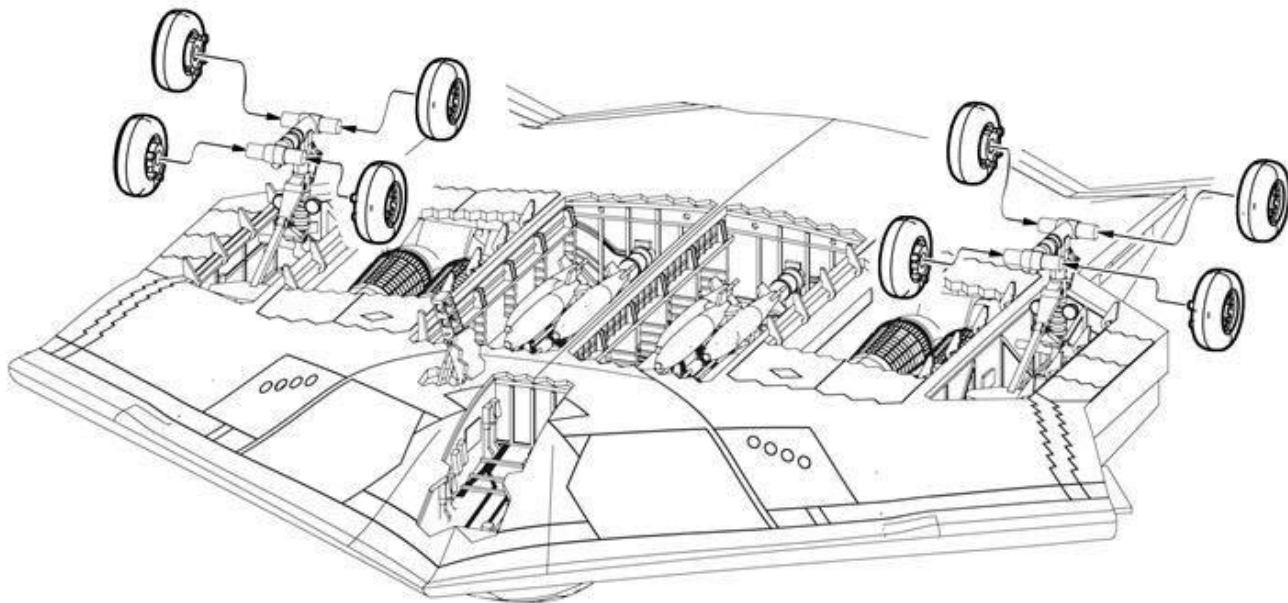
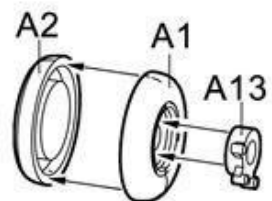

31 综合投弹空气控制板
综合投弹空气控制板
Attaching bomb bay air control panel

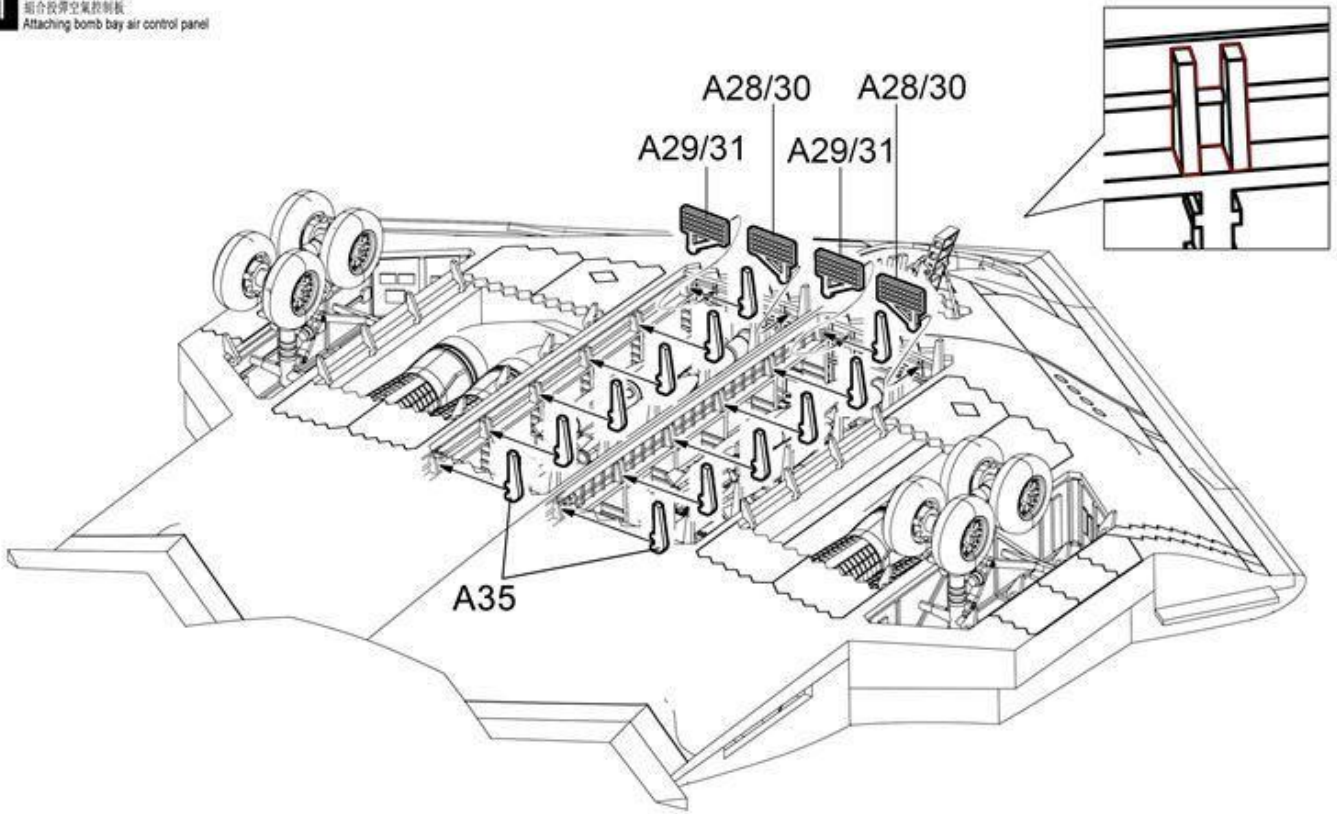

32 综合舱门
综合舱门
Attaching bomb bay door

Or close status

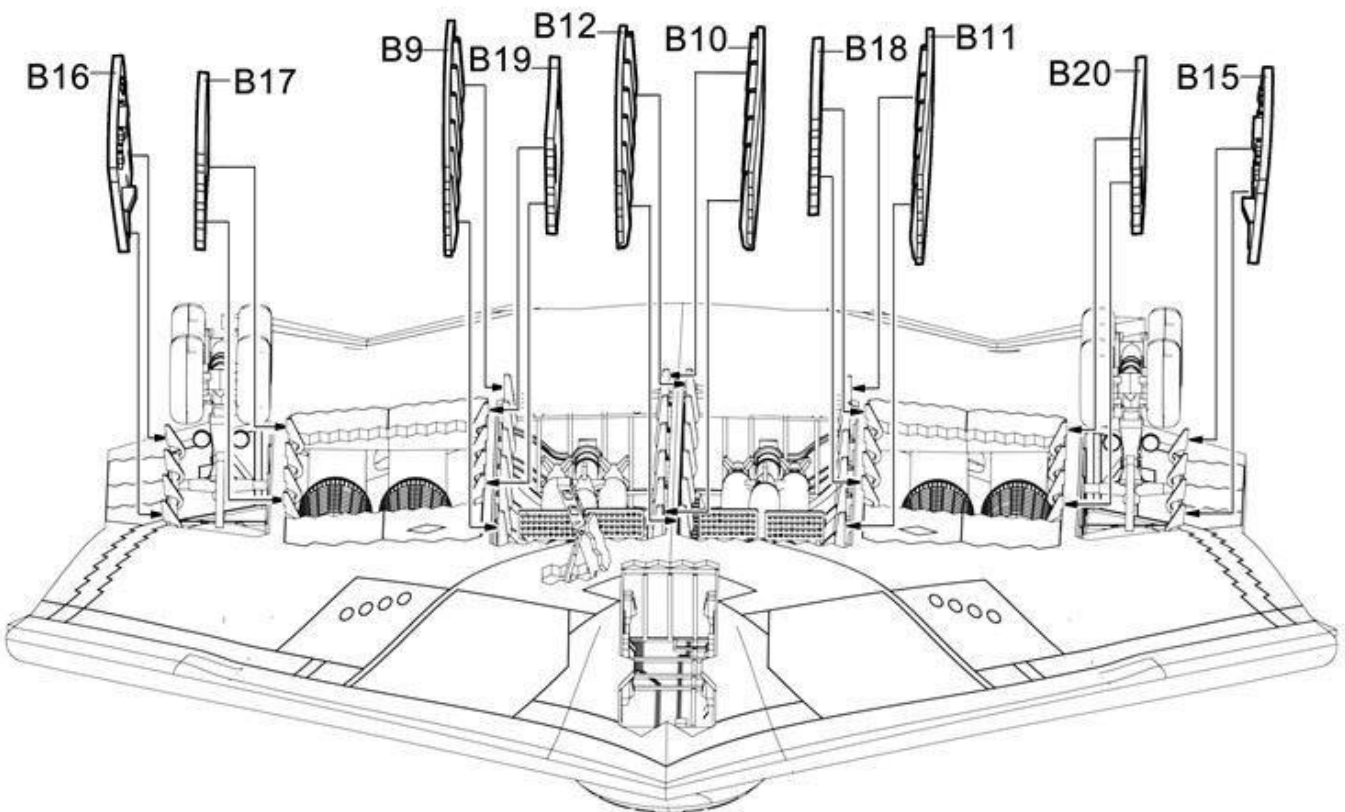
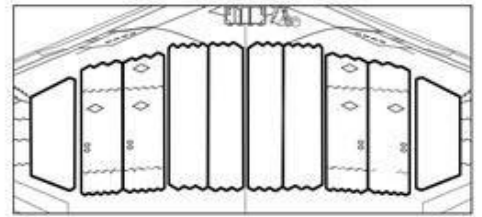

33 组合前起落架 2
组合前起落架 2
Attaching front landing gear

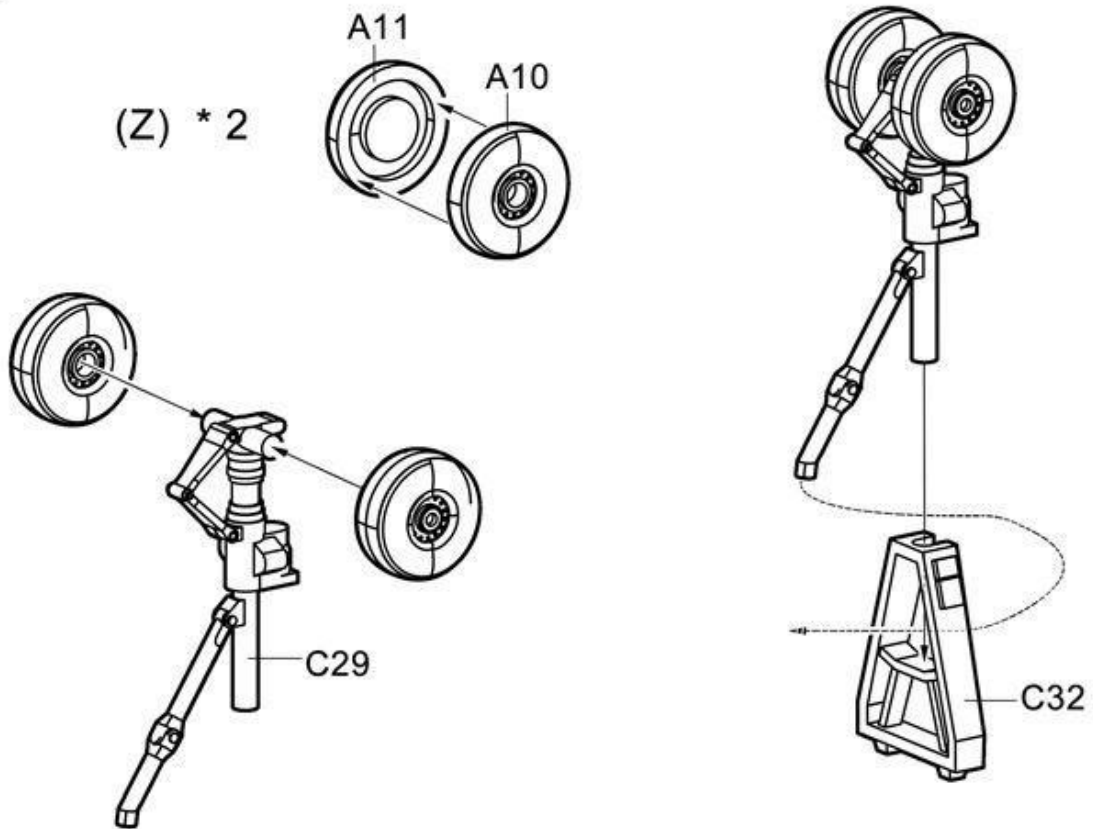

34 组合前起落架 3
组合前起落架 3
Attaching front landing gear

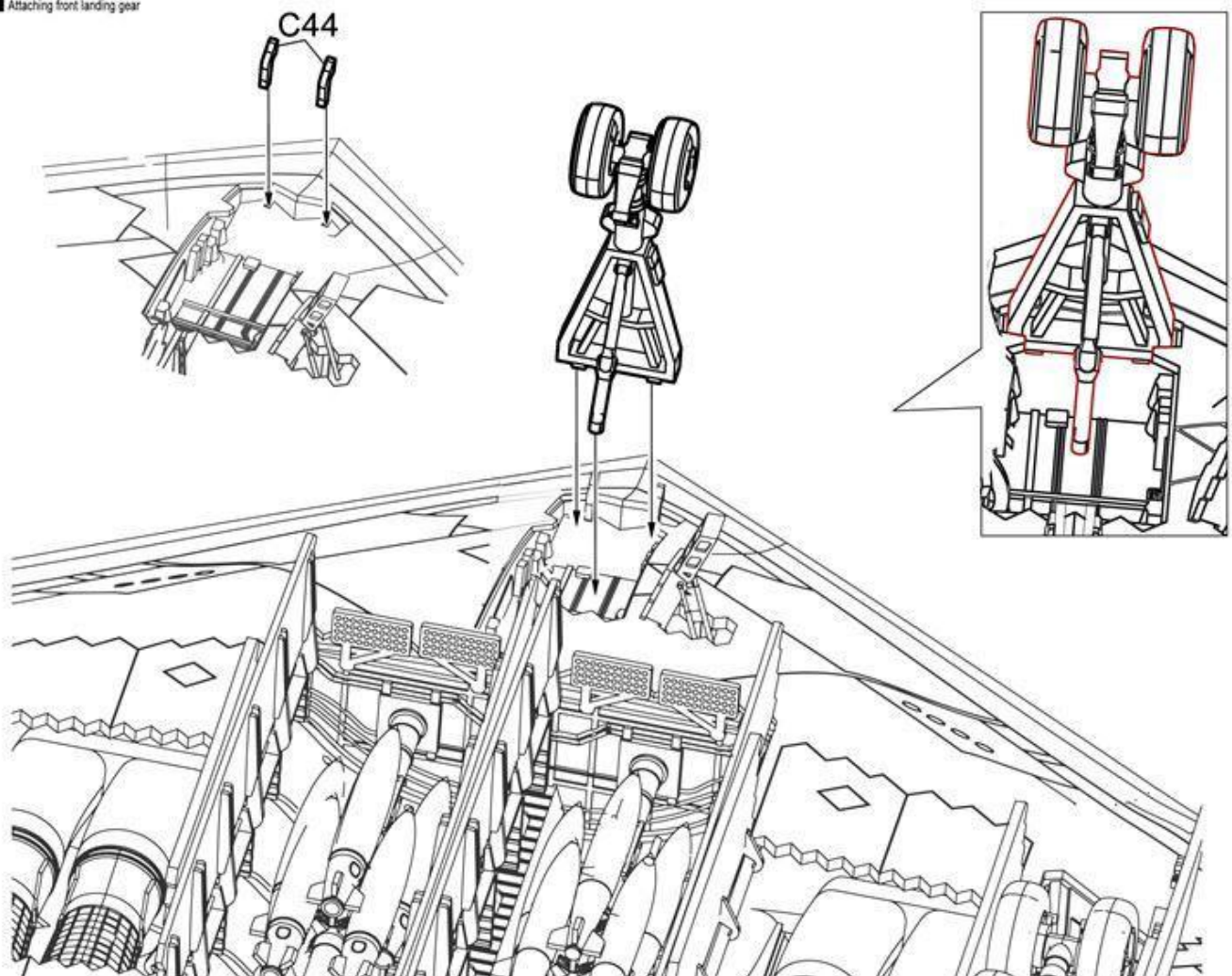

35 组合前起落架 4
Attaching front landing gear

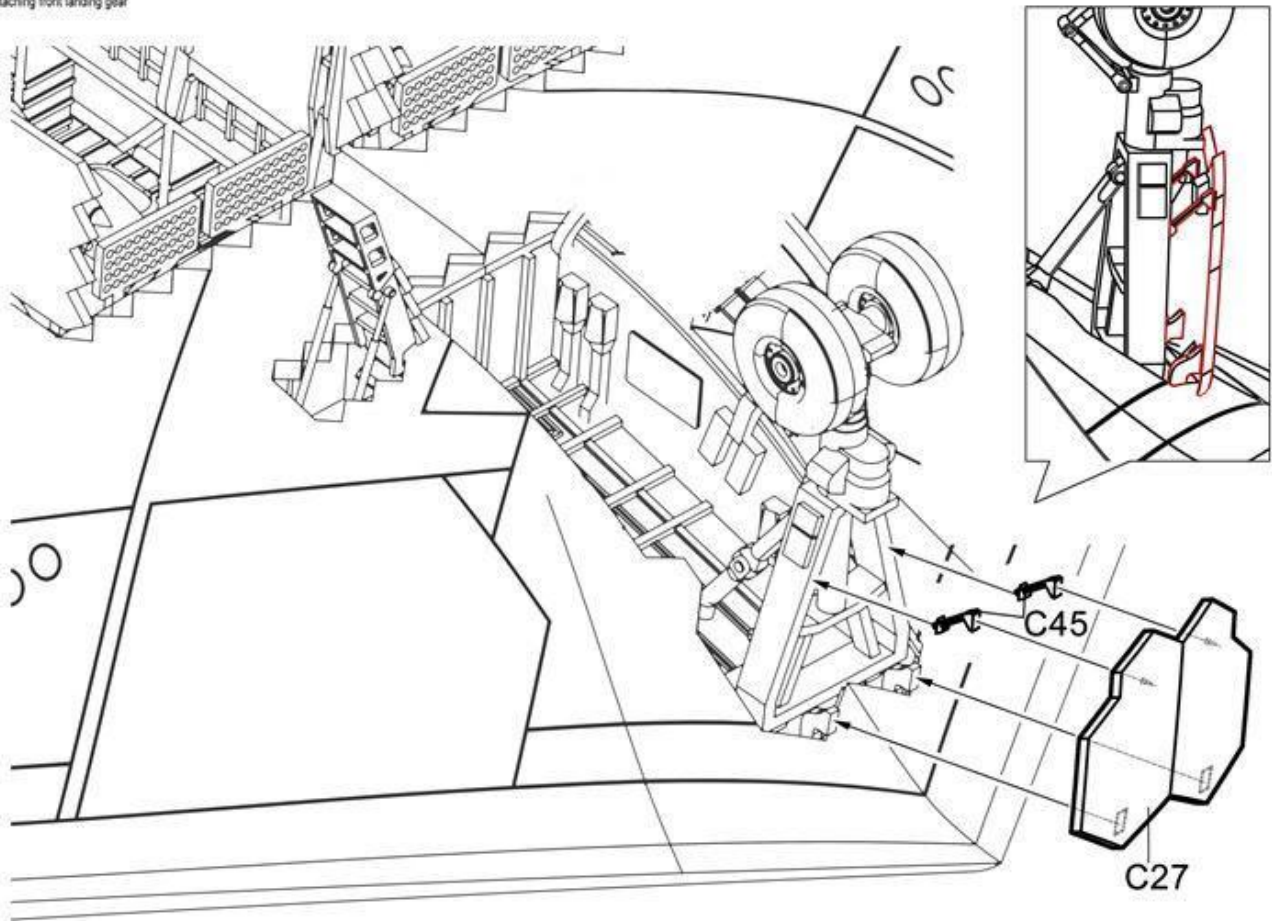

36 组合前起落架 1
Attaching front landing gear

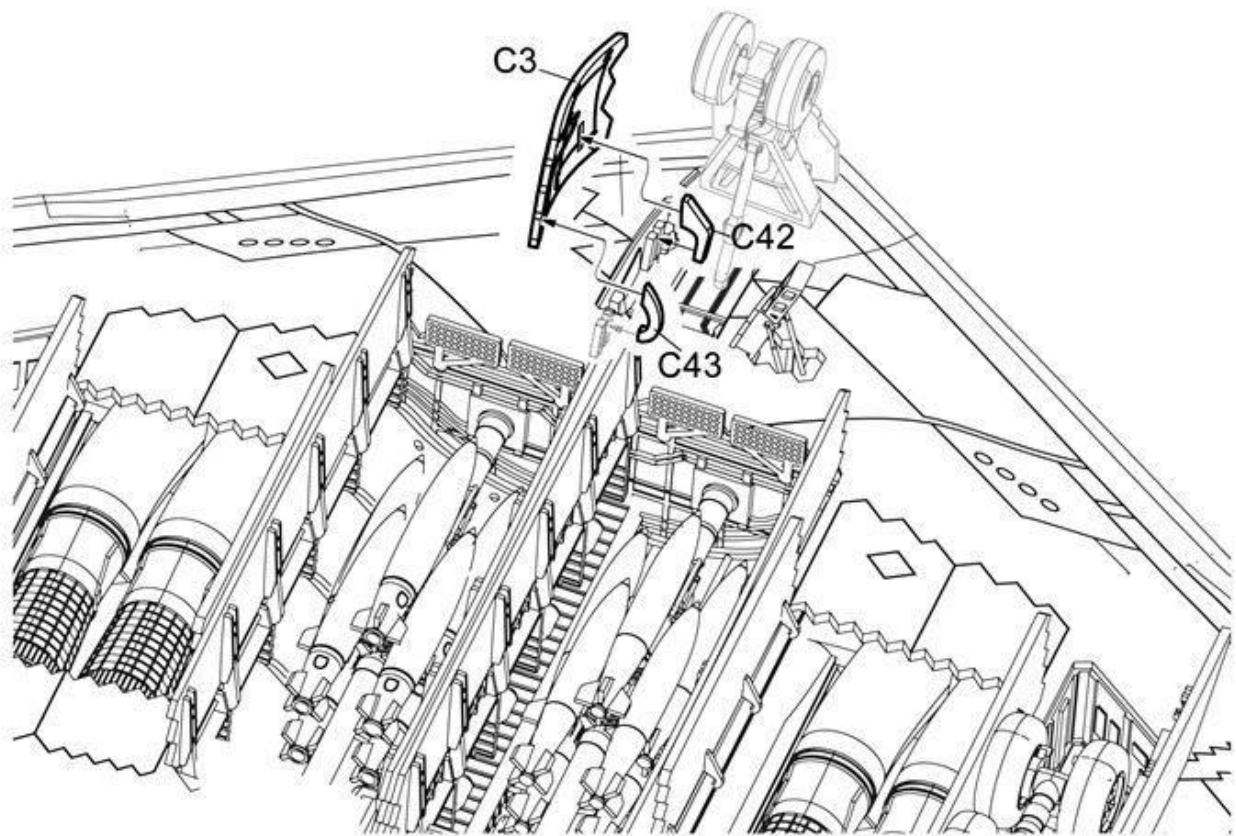

37 組合左機翼
組合左機翼
Attaching left wing

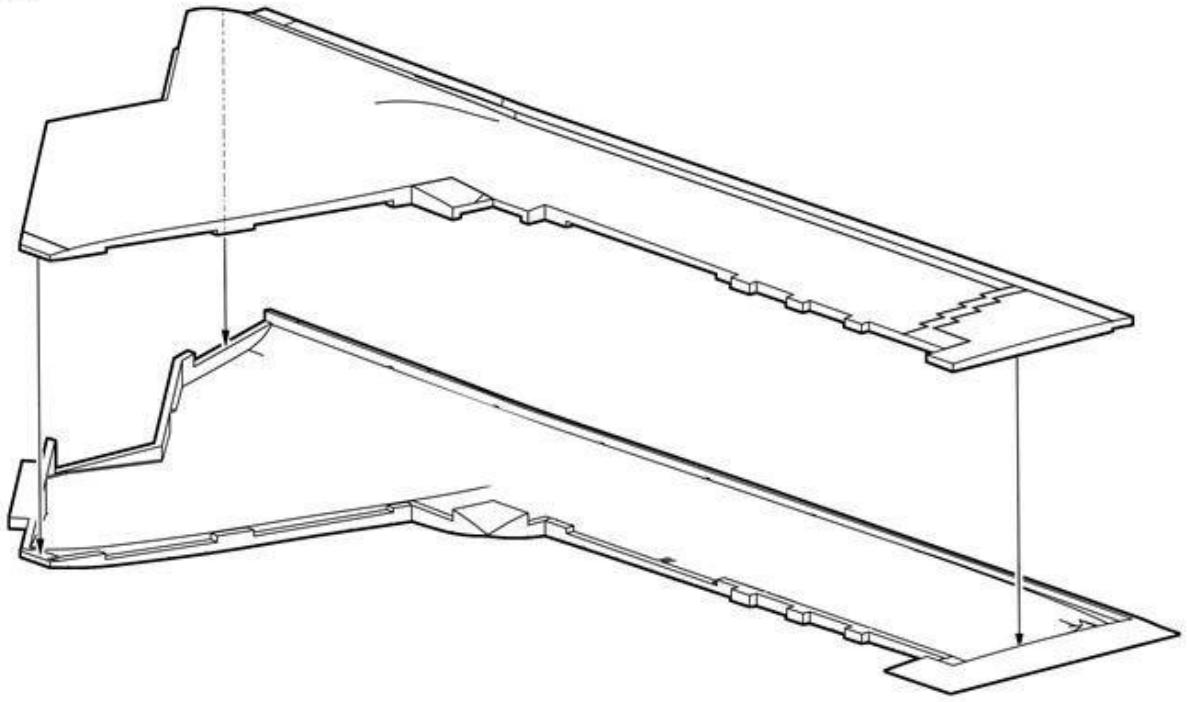

38 組合副翼
組合副翼
Attaching aileron

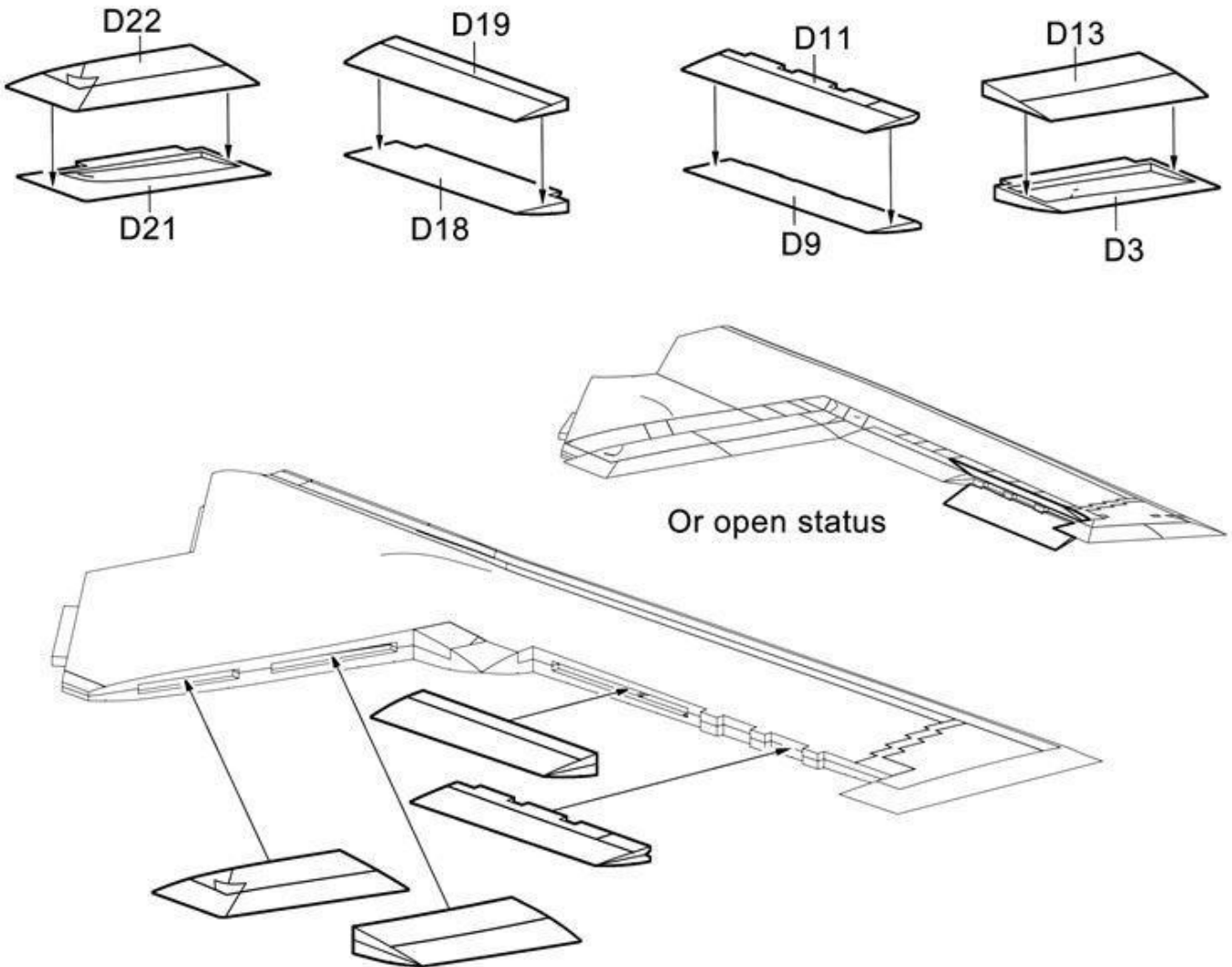

39

組合右機翼
組合右機翼
Attaching right wing

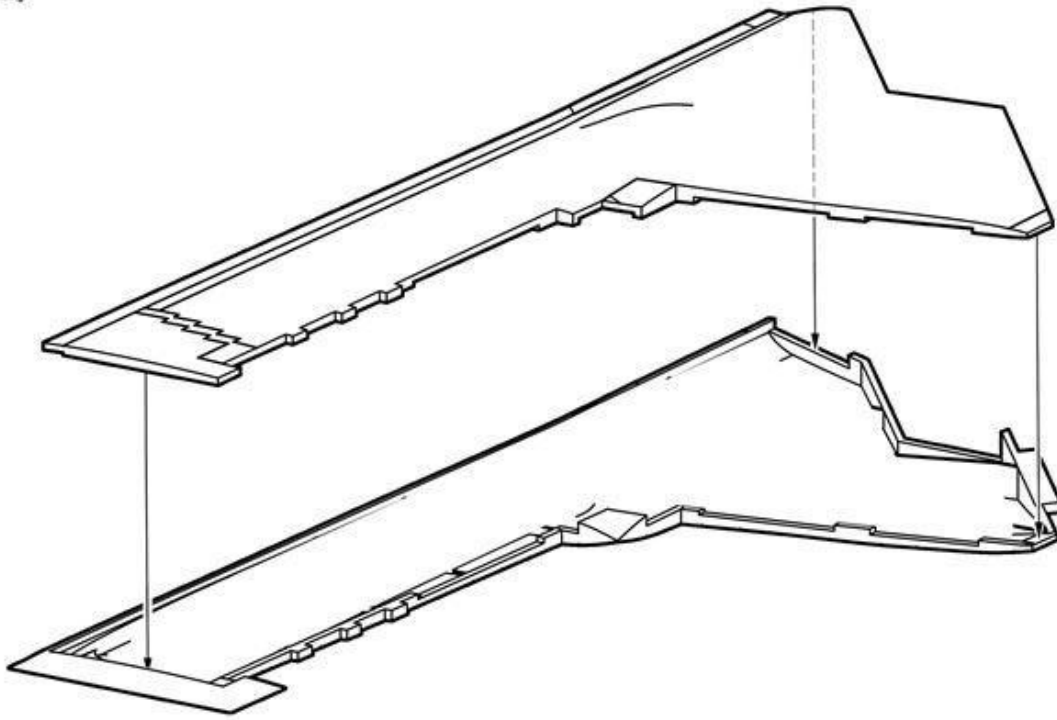

40

組合副翼
組合副翼
Attaching aileron

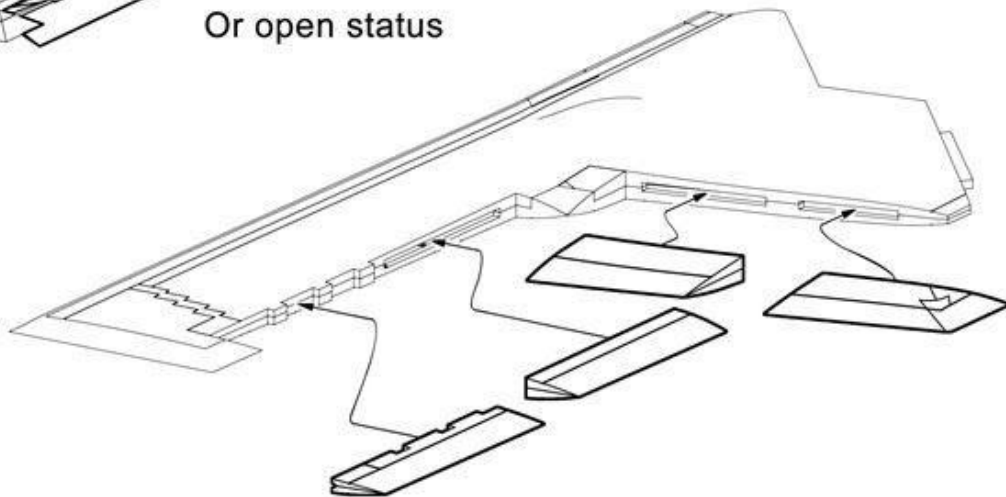
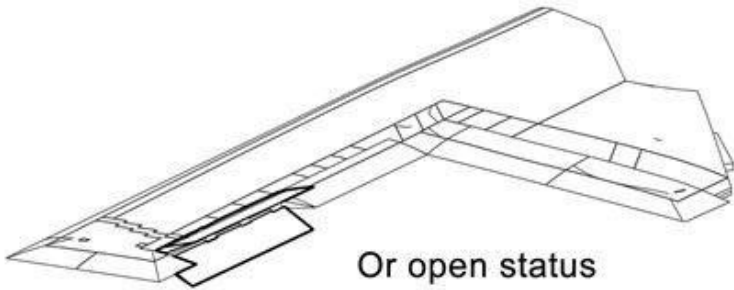
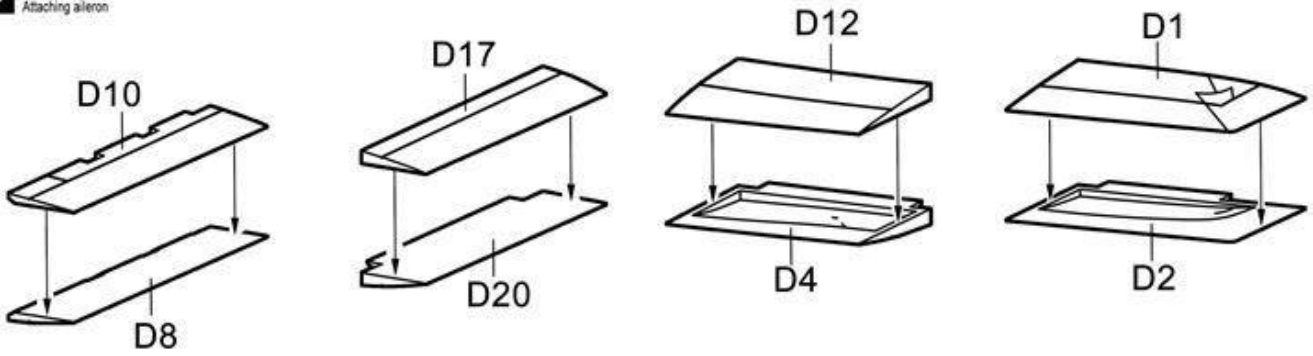

41 组合机翼与机体 1
组合机翼与机体 1
Attaching wing and body

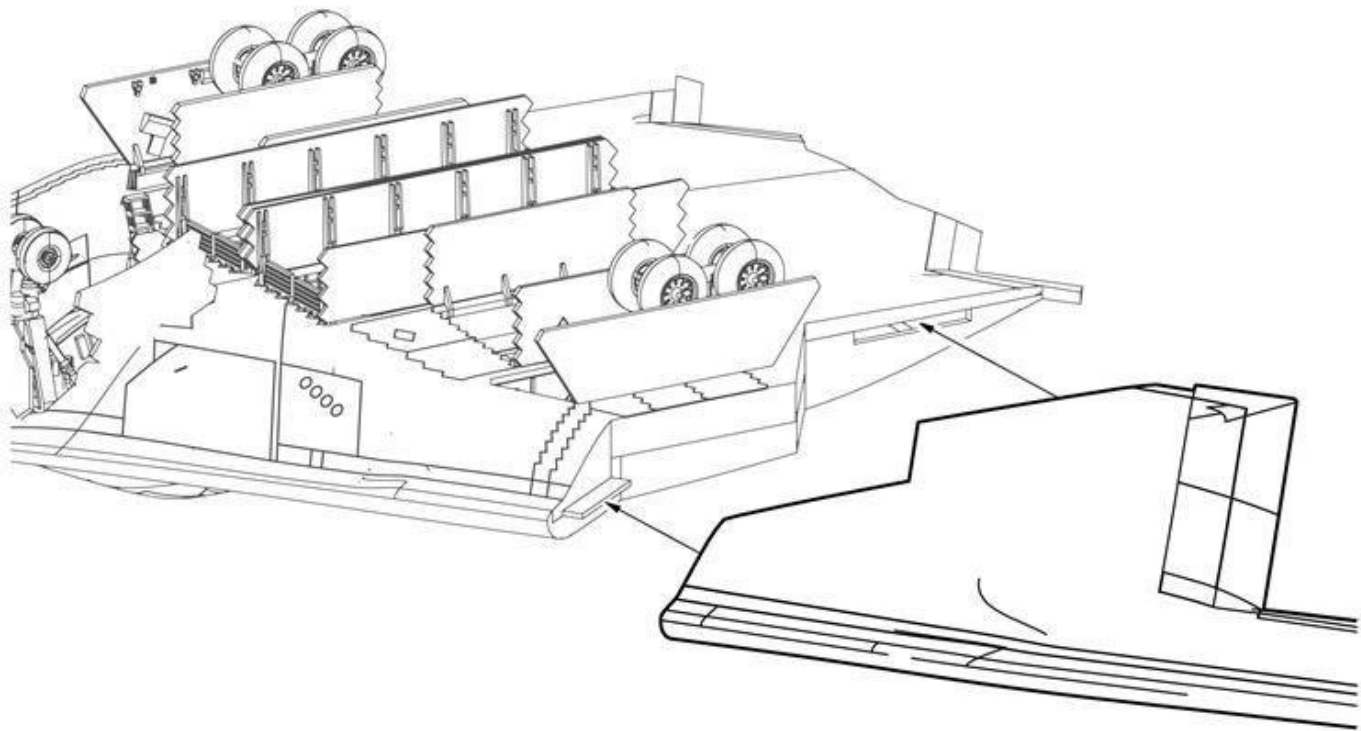

42 组合机翼与机体 2
组合机翼与机体 2
Attaching wing and body

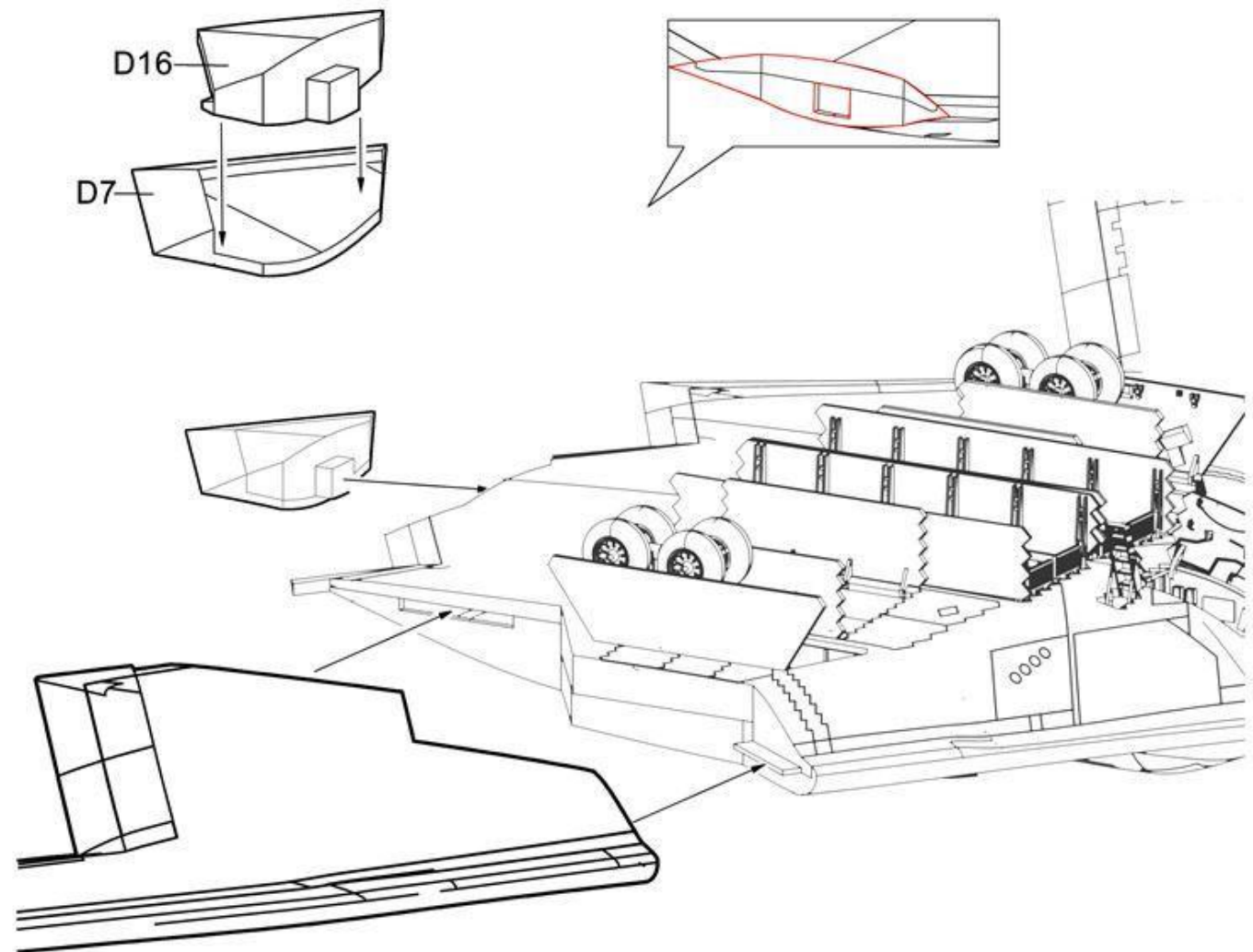

U.S.A.F B-2A SPIRIT STEALTH BOMBER

modelcollect

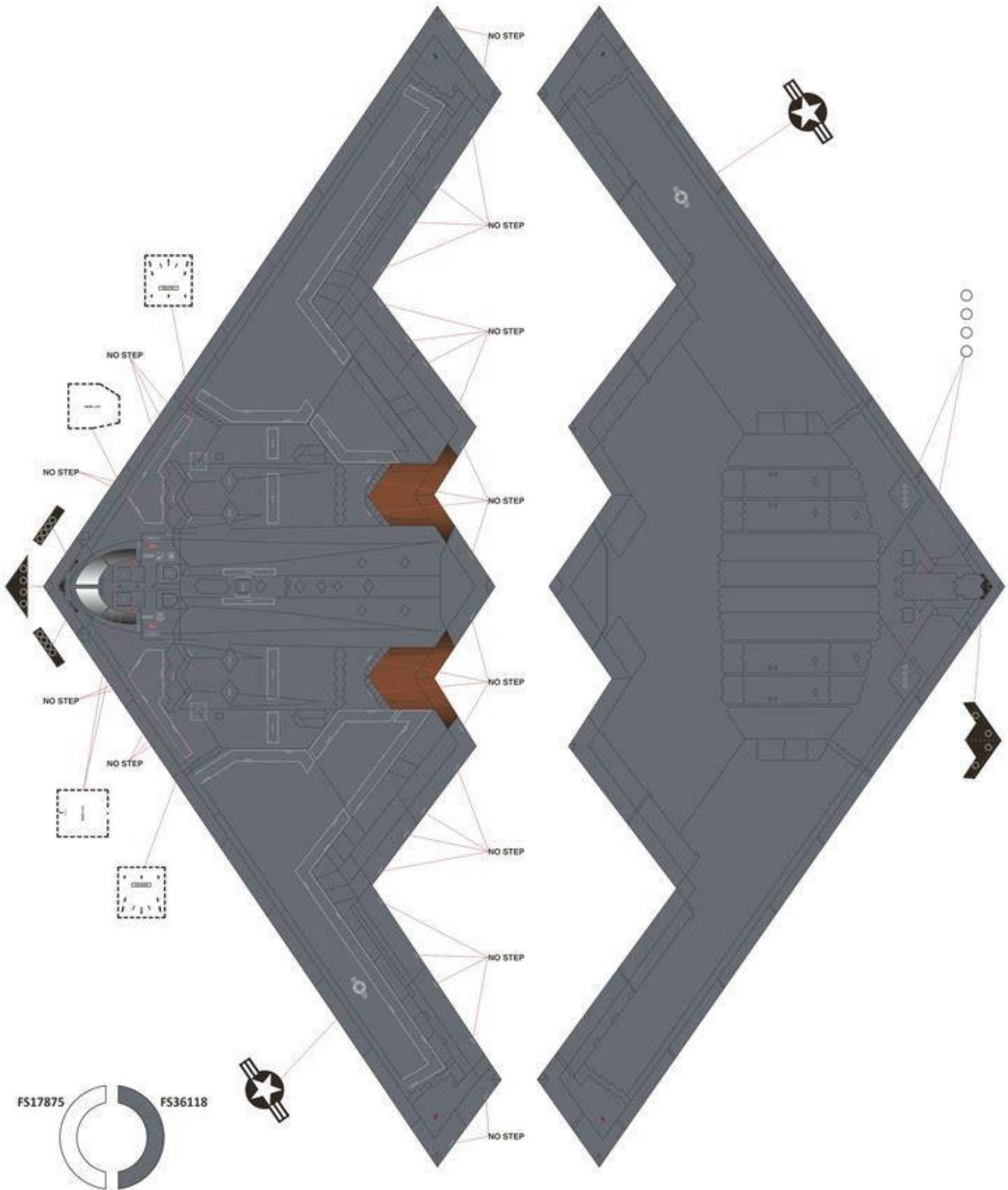

FS Color	Testors MM	Humbrol	Mr. Color	Xtracrylics	Mr. Paint
FS17875	1745	HU22	GUNC316	XA1141	MRP-099
FS36118	1723	HU125	GUNC305	XA1130	MRP-040

Decal artwork by **tb** TWO BOBS AVIATION GRAPHICS

MODELCollect

U.S.A.F B-2A SPIRIT STEALTH BOMBER

modelcollect

FS36118

FS17875

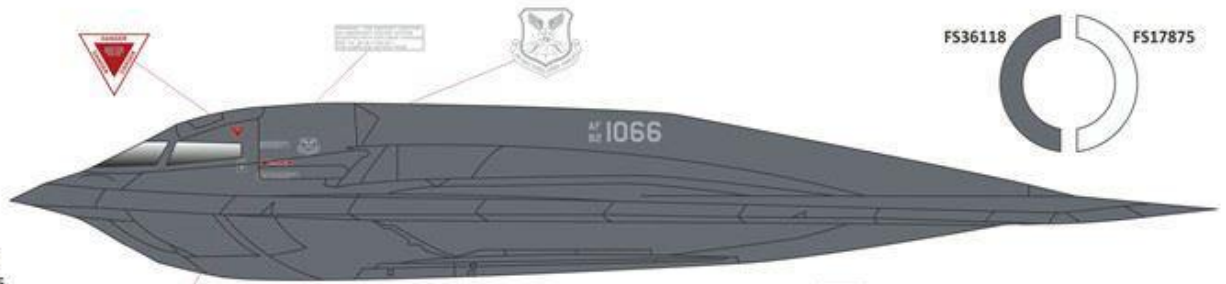

B-2A Spirit
SN 82-1066
Spirit of America
509th Bomb Wing
Whiteman AFB, MO
March 2012

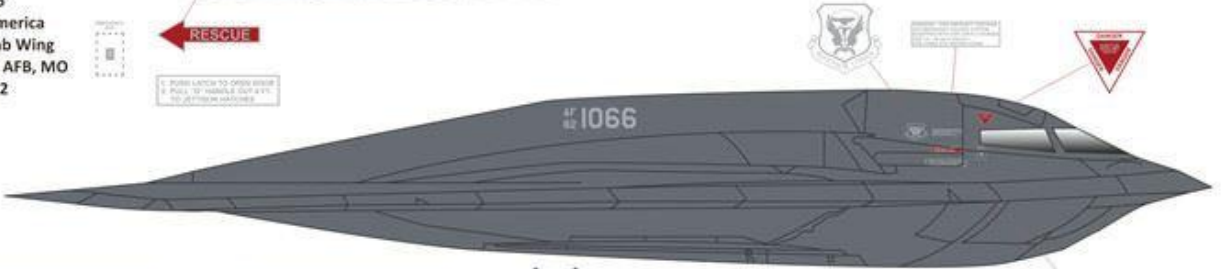

1. PUSH LATCH TO OPEN DOOR
2. PULL TO HANDLE FOR 5 FT.
TO AIRPORT OFFICES



B-2A Spirit
SN 82-1068
Spirit of New York
509th Bomb Wing
13th Bomb Squadron
Whiteman AFB, MO
July 2012

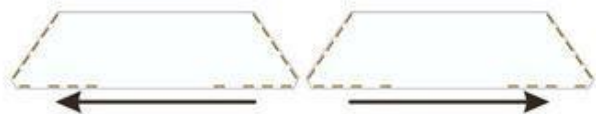

Note:
Inside of Gear Door Decals
All Wheels Wells are White



B-2A Spirit
SN 82-1071
Spirit of Mississippi
509th Bomb Wing
13th Bomb Squadron
Whiteman AFB, MO
October 2004



Decal Artwork by



MODEL COLLECT